

CJ2A Operation and Care Manual

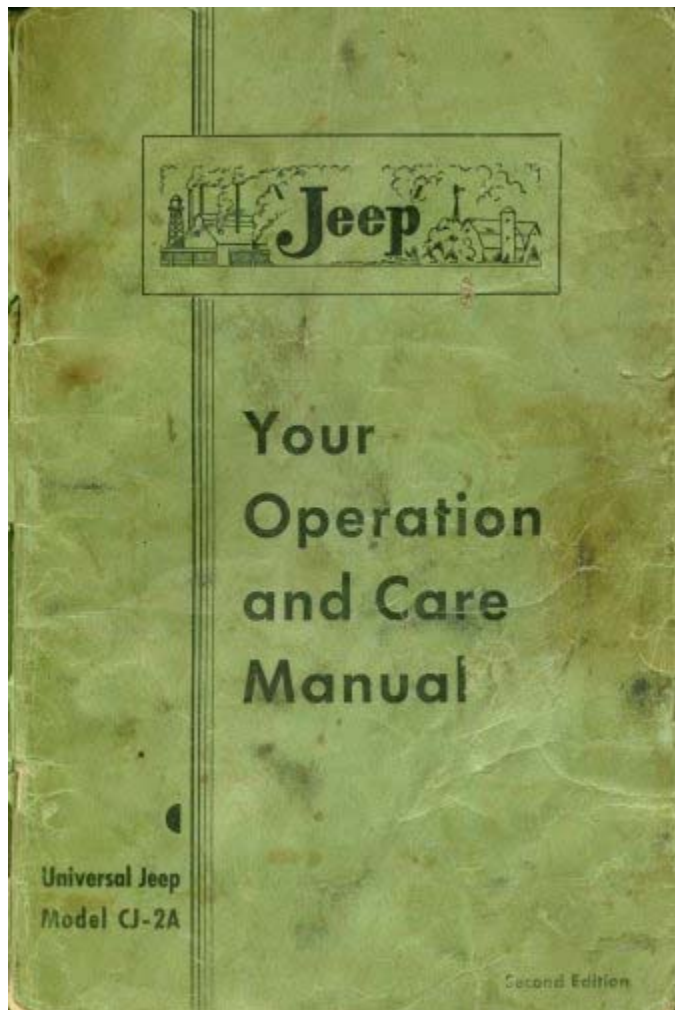

The information linked on this page was transcribed from an original 1946 Operation and Care Manual. Every effort has been made to insure its accuracy; however the author of this page assumes no responsibility for any errors or omissions, or any damages arising from the use of this transcribed Manual. In order to make it readable on the Internet, the format has been changed. For example, illustrations occasionally do not appear on the same page in the book as they do here. The author of this page hopes that the format of this "reprint" is acceptable to the reader. Owners of Willys-Overland Universal Jeeps, model CJ2A, and those with an historical interest in same, may freely print the Operation and Care Manual for their own

CJ2A

CJ2A Operation and Care Manual -- Foreword



Foreword

IN YOUR possession is a motor vehicle that has been thoroughly tested and inspected. Like any other piece of machinery, to maintain it in first class condition, you should lubricate it at the time prescribed with the proper grade of oil and grease and keep all working parts and oil holes clean and free of dirt and grit. You should also periodically have it systematically inspected at an Authorized Willys-Overland Service Station.

In the following pages we have set forth the knowledge every owner should have of his vehicle, that he may know to take the best care of it and handle it in such a way that he will get maximum service. Information is also available covering external adjustments and minor emergency repairs. Read and follow these instructions carefully; we are sure that you will then enjoy the satisfactory operation that you rightfully anticipate.

Should adjustment or repair seem necessary beyond your ability, don't experiment; have the work done by a competent repair man. It will always prove best and cheapest in the end to have the work done by the Dealer from whom you purchased your car. Many Willys-Overland Dealers have factory trained mechanics and all are familiar with the construction and adjustments through the cooperation of the manufacturer.

Do not attempt any adjustments as long as the vehicle is operating satisfactorily.

Be sure to obtain the Owner Service Policy, provided by your Dealer on delivery of your new vehicle.

Caution

Accept and use only Genuine Factory Parts

Imitation parts are usually of inferior quality and can do serious damage to other mechanical parts of your vehicle.

Genuine parts are sold by all authorized Willys-Overland Dealers. Be sure non other than genuine parts are placed in your vehicle.

Presence of parts other than those furnished by Willys-Overland will void the manufacturer's Warranty.

NOTE: Parts replaced under the terms of the Warranty must be left with the Willys-Overland Dealer who makes the replacement, if full credit is expected.

This is important for Owners to know, when traveling outside the territory in which their vehicle was originally purchased, particularly when credit for old parts cannot be established to the satisfaction of the Dealer.

In this connection, a forwarding address should be given by the Owner in order to insure the credit reaching him.

Standard Warranty

THE only Warranty under which new Willys-Overland Motor Vehicles are sold is that of the Manufacturer, being the Standard Warranty recommended by the Automobile Manufacturer's Association, and is as follows:

"This is to certify that we, WILLYS-OVERLAND MOTORS, INC., TOLEDO, OHIO, U.S.A. warrant each new motor vehicle manufactured by us, to be free from defects in material and workmanship under normal use and service, our obligations under this Warranty being limited to making good at our factory any part or parts thereof, including all equipment or trade accessories (except tires) supplied by the Car Manufacturer, which shall, within ninety (90) days after making delivery of such vehicle to the original purchaser or before such vehicle has been driven 4000 miles, whichever event shall first occur, be returned to us with transportation charges prepaid, and which our examination shall disclose to our satisfaction to have been thus defective; this warranty being expressly in lieu of all other warranties expressed or implied and of all other obligations or liabilities on our part, and we neither assume nor authorize any other person to assume for us any other liability in connection with the sale of our vehicles. This warranty shall not apply to any vehicle which shall have been repaired or altered outside of an Authorized Willys-Overland Service Station in any way so as, in the judgment of the Manufacturer, to affect its stability or reliability, nor which has been subject to misuse, negligence or accident"

The Manufacturer makes no warranty against, nor assumes any liability for any defect in metal or other material in any part, device or trade accessory which cannot be discovered by ordinary factory inspection.

WILLYS-OVERLAND MOTORS, INC.

NOTE -- Willys-Overland Motors, Inc., reserves the right at any time or times to revise, modify, discontinue or change any models of its vehicles, or any part or parts thereof, without notice; and, without it or the Seller, incurring any liability or obligation to the Purchaser.

[Return to The Top Page](#)

Chassis Lubrication	Chassis Lube.	No. 0	No. 1
Transmission and Transfer Case	Mineral Gear Oil	SAE 80	SAE 90
Differentials -- Front and Rear	Hypoid Oil	SAE 90	SAE 90
Steering Gear	Steering Gear Lube.	SAE 140	SAE 140
Wheel Bearings	Wheel Bearing Lube.	No. 2	No. 2
Universal Joints (Front Axle Shaft)	Universal Joint Lube.	No. 0	No. 1
Universal Joints (Propeller Shaft)	Chassis Lube.	No. 0	No. 1
Power Take-Off Housing	Mineral Gear Oil	SAE 80	SAE 90
Air Cleaner	Engine Oil	Same Grade as used in engine	Same Grade as used in engine
Governor	Engine Oil	Same Grade as used in engine	Same Grade as used in engine
Engine	Engine Oil	See Below	See Below

Above 90° F.....SAE 30
 Not Lower than 32° F...SAE 20 or 30
 As Low as +10° F.....SAE 20 W
 As Low as -10° F.....SAE 10 W
 To temperatures below -10° F, use SAE 10 W plus 10% kerosene.

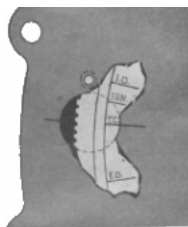

Fig. 4 FLYWHEEL
TIMING MARKS



FIG. 7 -- DISTRIBUTOR

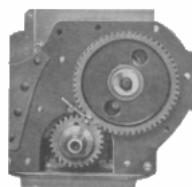

FIG. 8 TIMING GEAR MARKS

Valve and Ignition Timing

X
 X
 Inlet opens 9 degrees before top centre
 Inlet closes 50 degrees after bottom centre
 Exhaust opens 47 degrees before bottom centre
 Exhaust closes 12 degrees after top centre
 Spark Setting

 Spark set top centre with automatic spark controls at rest, when using low octane fuel.

 Firing Order
 Tappet setting for valve timing
 Number of flywheel teeth

Piston Measurements
From Top Centre
 .039" (9.91 mm.)
 3.772" (95.81 mm.)
 3.799" (96.49 mm.)
 .054" (0.14 mm.)
 "IGN" 5° BTC
 X
 X
 X
 X
 1-3-4-2
 .020" (0.51 mm.)
 97

* All specifications taken from *Your Operation and Care Manual Universal Jeep Model CJ-2A (second edition)* copyright 1946 by Willys-Overland Motors, Inc.

CJ2A Operation and Care Manual -- Inspections and Precautions



At assembly a restrictor is placed between the intake manifold and the carburetor to limit the road speed to approximately 42 mph. To protect the vehicle, leave the restrictor in position for the first 500 miles of road operation, or equivalent in industrial operation, after which remove and discard it.

It is an obligation of the Selling Dealer to carefully inspect and adjust your Universal Jeep before delivery. After your vehicle has been operated 1000 miles, return it to your dealer for the 1000 Mile Inspection in accordance with Factory Form, Ser. 3455. This inspection is free with the exception of engine oil and anti-freeze solution used.

1000 Mile Free Inspection

Check steering system and front wheel alignment.
 Check spring clip nuts and spring shackles.
 Check rear axle for oil and leaks.
 Adjust body bolts.
 Test service and hand brakes -- inflate tires.
 Check cooling system for leaks and anti-freeze and fan belt adjustment.
 Adjust clutch pedal.
 Check operation of transmission and transfer case -- Check for oil level and leaks.
 Check battery, generator output, headlamps and horn.
 Tighten universal joint companion flange bolts.
 Check operation of ammeter, heat indicator, fuel and oil gauges.
 Tighten cylinder head nuts -- Check timing and distributor points.
 Set spark plugs -- Adjust carburetor -- Check throttle controls.
 Check engine for oil leaks -- Check fuel line connections.
 Adjust valve tappets, if required.
 Change engine oil (charge for oil) -- Lubricate vehicle.
 Clean and refill air cleaner.
 Clean fuel pump sump and strainer.
 Check extra equipment attaching screws -- Check for oil level and leaks.

FILL IN FOR YOUR REFERENCE

Vehicle Serial Number _____
 Engine Serial Number _____
 Purchase Date _____
 Ignition Key Number _____

WILLYS-OVERLAND MOTORS, INC.

Proper Operation

DRIVING A NEW "JEEP"

Do not run your "Universal Jeep" faster than 40 miles an hour for the first 500 miles or if used on the farm or for industrial operation, use care when pulling heavy loads in the lower gear ratios. If the vehicle is operated at high speeds while new or used for heavy pulling for a long period, the closely fitted parts might possibly become overheated, resulting in scored pistons, cylinders or burned bearings. During its entire life, never race the engine while making adjustments or when the vehicle is standing idle. If the vehicle is not properly lubricated, our Warranty is null and void. Be sure to have

your Willys-Overland Dealer inspect your vehicle at the end of 1000 miles or equivalent usage and every 2500 miles thereafter.

SPECIAL PRECAUTIONS

There are several points of difference between the Universal Jeep and a conventional vehicle to receive attention. As a general precaution and for your information we are listing these "cautions" below:

The Jeep is equipped with a transfer case and four-wheel drive to provide additional traction and a lower gear ratio for use on difficult terrain. Use the front wheel drive only when necessary. Consider the front wheel drive and the transfer case as a lower gear ratio than the standard transmission low gear and use it only when greater power is required.

The use of four-wheel drive on hard surfaced highways will result in rapid tire wear and hard shifting of the transfer case, particularly when the front wheels are steered even at a slight angle from the straight ahead position. If hard shifting occurs, disengage the clutch, start engine, shift transmission into reverse gear, back the vehicle a few feet, and disengage clutch. If transfer case is in low range, shift into high then shift front axle into "out" position (lever forward).

Two drain cocks are provided to drain the cooling system. A drain cock is located under the left side of the radiator, however, it is necessary to drain the cylinder block separately. The cylinder block drain is located at the right front corner of the block directly under the generator. Loosen the radiator cap to break the seal and permit complete draining.

Check the level of the lubricant often in the transmission and transfer case. Be sure the lubricant is at filler level in both units at all times.

As a standard, the clutch pedal is adjusted with 1" free travel. As the clutch wears this becomes less. Be sure that there is free travel at all times to prevent continuous operation of the clutch release bearing and rapid wear and slippage of the clutch. This adjustment is made by lengthening or shortening the clutch control cable.

The ventilator valve, mounted in the intake manifold, must be free to operate. If it is stuck open very uneven engine operation at low speed will result.

Be sure the exhaust manifold heat control valve is free at all times and the thermostatic control spring is above the stop.

Six screws are used to attach the front wheel brake backing plate and spindle to the spindle housing. These screws are standard in dimensions and thread pitch, however, they are made of special steel and receive special heat treatment. Safety demands that only genuine factory screws be used at this point.

[Return to The CJ2A Home Page](#)

CJ2A Operation and Care Manual -- Getting Started

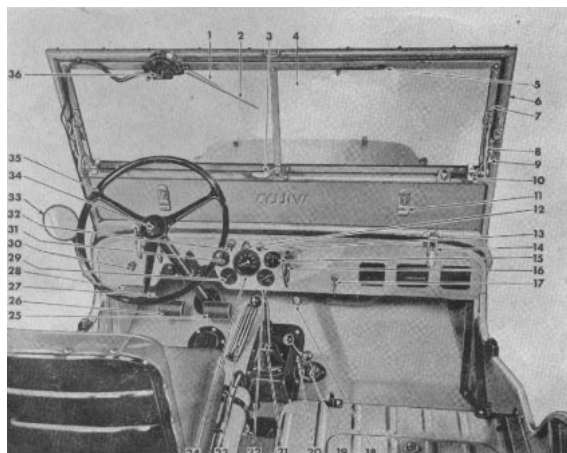

FIG. 1 - VEHICLE CONTROLS

- | | |
|--|-----------------------------------|
| 1. Windshield Wiper Arm | 19. Underdrive Shift Lever |
| 2. Windshield Wiper Blade | 20. Front Axle Drive Shift Lever |
| 3. Windshield Centre Lock | 21. Transmission Shift Lever |
| 4. Windshield Glass | 22. Heat Indicator Gauge |
| 5. Hand Wiper Handle and Knob | 23. Accelerator Pedal |
| 6. Windshield Tubular Frame | 24. Speedometer |
| 7. Windshield Frame and Glass Assembly | 25. Brake Pedal |
| 8. Windshield Inner Adjusting Arm | 26. Clutch Pedal |
| 9. Windshield Outer Adjusting Arm | 27. Headlamp Dimmer Switch |
| 10. Adjusting Wing Screw | 28. Instrument Panel Light Switch |
| 11. Top Bow Storage Retainer | 29. Oil Gauge |
| 12. Instrument Panel Light | 30. Main Lighting Switch |
| 13. Choke Control | 31. Fuel Gauge |
| 14. Windshield Clamp | 32. Throttle Control |
| 15. Ammeter | 33. Rear Vision Mirror |
| 16. Hand Brake Handle | 34. Horn Button |
| 17. Ignition Switch | 35. Steering Wheel |
| 18. Starter Switch | 36. Windshield Wiper Motor |

TO MAKE VEHICLE READY.

- Fill the radiator with clean, soft water.
- Put gasoline in the tank.
- Fill the oil reservoir through the filler pipe at the right side of the engine until the oil indicator stick registers "FULL". (See "Lubrication Specifications".)
- Supply all parts requiring lubrication with oil or lubricant.
- See that the tires have proper pressure (See "Tire Pressure".)
- Adjust the rear view mirror to correct position for driver. If adequate view is not obtainable, the mirror may be adjusted by loosening the screw through the mounting bracket or by tilting in the ball and socket connection.

CONTROLS AND SWITCHES.

- The position of all controls and switches is shown in Fig. 1.
- The horn is operated by pressing the button located at the top center of the steering wheel.
- The instrument panel light switch is located along the lower edge of the instrument panel to the left of the steering post. The windshield wiper control is mounted on the wiper motor housing.
- The main light switch No. 30 controlling both the head and tail lamps is conveniently located on the instrument panel to the left of the steering post. It is of the plunger type – pull all the way out for the "full on" position, half-way for "parking" and all the way in is the "off" position.
- In addition to the main light switch, the high and low beams of the headlamps are controlled by a selector foot switch, located on the toe board to the left of the clutch pedal. Pressing and releasing the switch button, with the foot, alternately changes the beam from high to low and vice versa.

TO START ENGINE.

- Put the transmission gearshift lever No. 21, Fig. 1 in neutral. Place the transfer case low and high shift lever No. 19 in direct gear or in the rear position and disengage the front axle by placing the shift lever No. 29 in the forward position.
- Pull the choke control button No. 13 one-fourth of the way out which also opens the throttle slightly.
- Place the key in ignition lock No. 17 and turn it to the right, closing the ignition circuit.
- Disengage the clutch.
- Depress the foot starting switch at No. 18.
- Should the engine fail to start at once, pull the choke all the way out and press the starting switch. When the engine starts, push the choke in about one-third of the way.
- Set the choke control at the best operating position and as the engine warms up, push the choke all the way in. Do not run with the choke out as fuel is wasted and the engine fouled.
- Should the engine fail to start, see the "Emergency Chart".

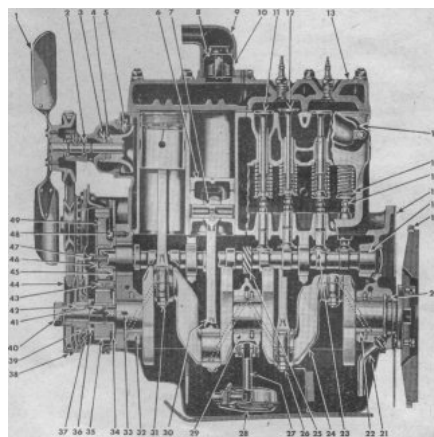

FIG. 2 -- SIDE SECTIONAL VIEW OF ENGINE

- | | | | |
|--|---|--|--|
| 1. Fan Assembly | 14. Exhaust Manifold Assembly | 26. Connecting Rod Cap Bolt | 39. Crankshaft Oil Seal |
| 2. Water Pump Bearing and Shaft Assembly | 15. Valve Spring | 27. Oil Float Support | 40. Starting Crank Nut Assembly |
| 3. Water Pump Seal Washer | 16. Valve Tappet Self-Locking Adjusting Screw | 28. Oil Float Assembly | 41. Crankshaft Gear Key |
| 4. Water Pump Seal Assembly | 17. Engine Plate -- Rear | 29. Crankshaft Bearing Centre -- Lower | 42. Fan and Governor Drive Pulley Key |
| 5. Water Pump Impeller | 18. Camshaft | 30. Connecting Rod Assembly -- No. 2 | 43. Timing Gear Oil Jet |
| 6. Piston | 19. Flywheel Ring Gear | 31. Connecting Rod Bolt Nut Lock | 44. Fan, Generator and Governor Drive Pulley |
| 7. Wrist Pin | 20. Crankshaft Packing -- Rear End | 32. Crankshaft Bearing -- Front Lower | 45. Camshaft Thrust Plate |
| 8. Thermostat Assembly | 21. Crankshaft Bearing Rear Drain Pipe | 33. Crankshaft Oil Passages | 46. Camshaft gear Retaining Washer |
| 9. Water Outlet Elbow | 22. Crankshaft Bearing -- Lower | 34. Crankshaft Thrust Washer | 47. Camshaft Gear Retaining Screw |
| 10. Thermostat Retainer | 23. Valve Tappet | 35. Crankshaft Gear | 48. Camshaft Gear Thrust Plate Retaining Screw |
| 11. Exhaust Valve | 24. Crankshaft | 36. Crankshaft Gear Spacer | 49. Camshaft Gear |
| 12. Intake Valve | 25. Oil Pump and Distributor Drive Gear | 37. Timing Gear Cover Assembly | |
| 13. Cylinder Head | | 38. Fan and Generator Drive Belt | |

TO START VEHICLE.

- Release hand brake, if set.
- Depress clutch pedal.
- Move transmission gearshift lever to first speed position – see Fig. 3 (Note that the front axle and transfer case shift levers are not used when the vehicle is driven on the highway in rear wheel drive.)
- Depress the foot accelerator pedal gradually and at the same time, slowly release the clutch pedal.
- Allow the vehicle to gain momentum (two or three vehicle lengths), then release the accelerator and depress the clutch at the same moment.
- Move the shift lever promptly to the second speed position.
- Depress the foot accelerator pedal gradually and at the same time, slowly release the clutch pedal.
- Shift to third or "high" speed in the same way at approximately 18 to 20 mph, releasing the accelerator and depressing the clutch before moving the shift lever.
- The synchronizing mechanism in the transmission makes gear shifting silent and easy. This device adjusts the speeds of the two gears to be engaged and prevents "clashing".

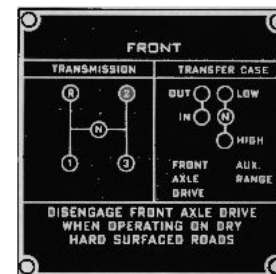

FIG. 3 -- SHIFT

TO CHANGE TO LOWER SPEED.

- Depress the clutch pedal.
- Move the gearshift lever quickly to the next lower speed, increasing the engine speed slightly, if traveling on level road and release the clutch pedal.
- It will be found advisable to make this change when the engine is placed under heavy pull, or when dropping down to a very low speed, as when travelling up a steep grade, in sand or in congested traffic.
- Never attempt to make the change with the vehicle traveling at a high rate of speed.

TO STOP THE VEHICLE.

- Release the foot accelerator.
- Depress the clutch pedal and apply foot brake.
- When stopped, move gearshift lever into neutral.
- Set the hand brake and release the clutch and brake pedals.

TO REVERSE VEHICLE.

- With the vehicle at a standstill, depress the clutch pedal.
- Shift the lever into the reverse position, slowly release the clutch pedal and regulate the car speed with the foot accelerator.

TO USE THE ENGINE AS A BRAKE.

The most effective brake for holding the vehicle back on a steep grade is the engine. To use the engine as a brake, shift into one of the lower speeds before starting to descend. Keep the clutch engaged, the throttle closed, and the ignition "ON". Low gear will hold any vehicle effectively on any hill it can climb.

Never engage the clutch suddenly when the vehicle is coasting with the clutch released and the transmission gears in mesh, as damage to the driving mechanism may result.

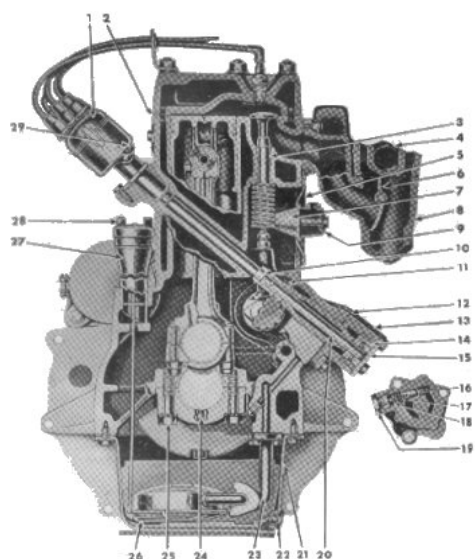

FIG. 4 -- END SECTIONAL VIEW OF ENGINE

- | | |
|---|---|
| 1. Ignition Distributor | X |
| 2. Cylinder Head Gasket | X |
| 3. Exhaust Valve Guide | |
| 4. Intake Manifold Assembly | |
| 5. Valve Spring Cover Assembly | |
| 6. Heat Control Valve | |
| 7. Crankcase Ventilator Baffle | |
| 8. Exhaust Manifold Assembly | |
| 9. Crankcase Ventilator Assembly | |
| 10. Distributor Shaft Friction Spring | |
| 11. Oil Pump Driven Gear | |
| 12. Oil Pump Gasket | |
| 13. Oil Pump Assembly | |
| 14. Oil Pump Pinion | |
| 15. Oil Pump Cover | |
| 16. Oil Pump Relief Plunger | |
| 17. Oil Pump Relief Plunger Spring | |
| 18. Oil Pump Relief Plunger Shim | |
| 19. Oil Pump Relief Plunger Spring Retainer | |
| 20. Oil Pump Shaft | |
| | 21. Oil Pan Assembly |
| | 22. Oil Pan Drain Plug |
| | 23. Oil Float Support |
| | 24. Crankshaft Bearing Dowel |
| | 25. Crankshaft Bearing Cap to Crankcase Screw |
| | 26. Oil Float Assembly |
| | 27. Oil Filler Tube |
| | 28. Oil Filler Cap and Level Indicator |
| | 29. Distributor Oiler |

STARTING VEHICLE ON UPGRADE.

In starting on an upgrade, hold the vehicle with the hand brake, disengage the clutch and shift the transmission into low speed, then accelerate the engine with the foot accelerator in the regular way while simultaneously releasing the hand brake and engaging the clutch.

SHIFTING GEAR IN TRANSFER CASE.

The transfer case is essentially a two speed transmission, which provides a low and a direct gear and also a means of connecting the engine power to the front axle. It is an auxiliary unit attached to the rear of the standard transmission.

Control of the transfer case is through the two shift levers, Fig. 1 No. 19 and No. 20. The left lever, No. 20, is used to connect and disconnect the power to the front axle. The right lever, No. 19 is used to shift the transfer case gears to secure either "High" (direct drive) or a very low gear ratio for heavy pulling requirements.

Instructions for shifting gears in the transfer case are as follows: See Fig. 3.

1. To engage front axle drive, depress the clutch pedal, release accelerator and move the left hand shift lever (No. 20) to rear position.
2. With the front axle drive engaged, the right hand lever (No. 19) may be shifted to the rear into "High" (direct) or forward into "Low". The "Neutral" position midway between "High" and "Low" is for use when the power take-off belt drive is used. The vehicle cannot be driven when this lever is in "Neutral".
3. To disengage the front axle drive, depress the clutch pedal, release the accelerator and shift the left lever to the forward position. The transfer case can be operated only in "High" (direct drive) when the front axle drive is disengaged.
4. Shifting from high to low transfer case gear should not be attempted except when the vehicle is practically at a standstill. The front axle drive must be engaged for this shift. Release the accelerator and depress the clutch pedal – move the left hand shift lever to the rear position to engage the front wheel drive, then move the right hand shift lever to forward position (low transfer case gear).
5. Shifting from low to high transfer case gear may be accomplished at any time, regardless of vehicle speed. Release accelerator and depress clutch pedal and shift right hand lever into rear position.

USE OF FOUR WHEEL DRIVE.

The "Universal Jeep" is equipped with four-wheel drive and transfer case to provide additional traction and a low gear ratio for use on difficult terrain and to provide low speed pulling power for industrial and agricultural use. Four-wheel drive should be used only when greater traction and power are required than provided by the standard transmission and low gear.

Avoid the use of four-wheel drive on hard surfaced highways as it will result in rapid tire wear and hard shifting of the transfer case gears. Should hard shifting occur, disengage the clutch, start engine, shift the transmission into reverse gear, back the vehicle a few feet, and disengage the clutch. If transfer case is in low range, shift into high, then disengage front axle drive (left lever forward).

STEERING KNUCKLE OIL SEAL.

When parking during cold, wet weather, swing the front wheels from right to left to wipe away moisture adhering to the front axle universal joint housings and oil seals, Fig. 5. This will prevent freezing with resulting damage to the oil seal felts. When the vehicle is stored for any period, the front axle universal joint housings should be coated with light grease to prevent rusting.

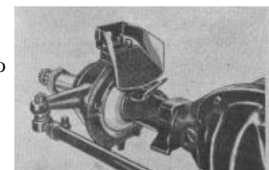

How to Save Gasoline

1. In cold weather economical starting of the engine is easily obtained by pressing down on the accelerator pedal once or twice, then push down on the clutch pedal and start engine using the choke sparingly. Do not use the choke when starting a warm engine.
2. Do not use the choke excessively while engine is warming up and never leave it out longer than absolutely necessary.
3. Accelerate gently. Tramping on the accelerator pumps more gasoline into the cylinders than can be effectively used.
4. Holding the car in second gear until you get up to high speeds may easily double the gasoline you should use in getting under way. Shift into high gear at about 20 miles per hour.
5. Fast driving uses up more gasoline. Travel at moderate speeds if you want gasoline economy.
6. Decelerate to a gradual stop. Sudden stops, like sudden starts, are wasteful of gasoline.
7. Park your car in the shade if possible, hot sun evaporates gasoline.
8. Don't drive your tires with less than the proper amount of air pressure. Under-inflated tires mean more road friction, more work for the engine to do -- and therefore more gasoline consumed. See "Tire Pressure".
9. Keep the battery charged up in good condition. It helps starting and provides good ignition thereby reducing loss of gasoline.
10. Letting the engine idle for long periods wastes gasoline.
11. Be sure that the carburetor is in proper condition for maximum mileage and power.
12. One faulty or dirty spark plug may waste as much as 10 percent of your gasoline. Have the spark plugs tested occasionally.
13. Keep your car well lubricated at all times, and be very careful to follow the instructions on "Lubrication".
14. Keep the radiator filled to the proper level; your engine will remain at a more constant temperature. An overheated engine uses more gasoline.
15. Check the operation of the automatic heat control on the exhaust manifold. The purpose of this heater is to warm the mixture of air and gasoline as it leaves the carburetor, in order to give better vaporization. (See Manifold Heat Control).
16. It is a good idea to have a complete engine tune-up every 5,000 miles, or at least twice a year -- in the Fall when preparing for Winter driving and again in the Spring. The Owner Service Policy entitles you to an adjustment and complete inspection without charge at the end of the first 1000 miles.

[Return to The CJ2A Home Page](#)

CJ2A Operation and Care Manual -- General Lubrication



General Lubrication

The use of high grade lubricants and regular application is specially essential when operating the “Jeep” because of the diversified service it performs. The amount of trouble free service received will be in proportion to the care given. Lubricate the vehicle in accordance with the type of service performed.

The following pages should be referred to for instructions covering grade and quality of lubricant for all parts of the vehicle. The mileage instructions should be followed when the vehicle is used for road work. It is impossible to give accurate hourly instructions because of the diversified service and conditions under which the vehicle may be operated. The hours indicated are approximate. To obtain maximum service, good judgment must be used to lubricate the vehicle according to the type of work being done. As an example – when used as a farm tractor under dusty conditions the chassis should be lubricated daily as the new lubrication forces grit and dirt, which has accumulated during the day, from the bearing surfaces. Under these conditions, the air cleaner should also be cleaned and refilled daily or under extreme conditions twice daily.

Because of the importance of correct lubrication, detailed recommendations, unit capacities and specifications are given in the following paragraphs. [Also see Fig. 17, LUBRICATION CHART](#)

Lubrication Specifications

	Type Lube.	Winter	Summer
Chassis Lubrication	Chassis Lube.	No. 0	No. 1
Transmission and Transfer Case	Mineral Gear Oil	SAE 80	SAE 90
Differentials -- Front and Rear	Hypoid Oil	SAE 90	SAE 90
Steering Gear	Steering Gear Lube.	SAE 140	SAE 140
Wheel Bearings	Wheel Bearing Lube.	No. 2	No. 2
Universal Joints (Front Axle Shaft)	Universal Joint Lube.	No. 0	No. 1
Universal Joints (Propeller Shaft)	Chassis Lube.	No. 0	No. 1
Power Take-Off Housing	Mineral Gear Oil	SAE 80	SAE 90
Air Cleaner	Engine Oil	Same Grade as used in engine	Same Grade as used in engine
Governor	Engine Oil	Same Grade as used in engine	Same Grade as used in engine
Engine	Engine Oil	See Below	See Below
Above 90° F.....	SAE 30		
Not Lower than 32° F...	SAE 20 or 30		
As Low as +10° F.....	SAE 20 W		

As Low as -10° F.....SAE 10 W

To temperatures below -10° F, use SAE 10 W plus 10% kerosene.

ENGINE LUBRICATION.

Lubrication of the engine is accomplished by means of a force-feed continuous circulating system. This is effected by means of a gear type pump, located externally on the left side of the engine, and driven by a spiral gear on the camshaft.

The oil is drawn into the circulating system through a floating oil intake. The floating intake does not permit water or dirt to circulate, which may have accumulated in the bottom of the oil pan, because the oil is drawn horizontally from near the top surface.

An oil pressure gauge is mounted in the instrument panel, which indicates the pressure being supplied to the circulating system. Failure of the gauge to register may indicate absence of oil, leakage or a fault in the lubrication system and the engine should be stopped immediately. If there is plenty of oil in the reservoir the mechanical fault must be corrected before starting the engine. Standard gauge reading is approximately 35 at 30 miles per hour and 10 at idle speed.

The quantity of the oil in the crankcase is measured by the bayonet type oil level indicator which is combined with the oil filler cap located in the oil filler pipe at the right side of the engine. When the oil level is below the "Full" mark, pour sufficient new oil into the reservoir to bring the level to the "Full" mark.

When the vehicle leaves the factory the crankcase is filled to the correct level with oil of the proper viscosity for the "break-in" period. When the vehicle is used on the highway, completely drain the engine oil at 500 miles and at 1000 miles, then every 2000 miles thereafter, by removing the drain plug in the lower left side of the oil pan. Replace the drain plug and refill with 4 qts. (5 qts. when the engine oil filter has been drained) of fresh oil. For heavy industrial or dusty field work, change the oil at the first 10 hours, and each 50 hours thereafter. To secure maximum engine life, watch the condition of the oil closely and should it become contaminated, due to conditions under which the vehicle has been operated, change it immediately.

Always drain the oil when the engine is warm. The benefit of draining is, to a large extent, lost if the crankcase is drained when the engine is cold, as some of the foreign matter will remain in the bottom of the oil pan.

At least once a year, preferably in the Spring, remove the oil pan and floating oil intake and wash thoroughly with cleaning solution.

CHASSIS LUBRICATION.

When lubricating the chassis refer to the Lubrication Chart. For highway travel, clean and lubricate points [2, 3, 4, 5, 6, 7, 8, 9, 10, and 11](#) each 1000 miles. When used in industrial or agricultural work the period for lubrication depends entirely upon the type of work being done. When doing dusty field work, lubricate these points daily as grit and dirt will work into the bearing surfaces and cause rapid wear unless forced out by new lubricant. The importance of using a good grade of chassis lubricant can not be exaggerated, for the cost will be more than repaid by longer wear and good service.

OIL FILTER.

The oil filter should be dismantled, cleaned and the filter element replaced at the end of the first 2000

miles of highway travel, or 100 hours of industrial or field use. Drain the filter at each oil change to prevent the old oil contained in the filter from mixing with and contaminating the new oil. Replace the element at each 8000 miles of highway use or 200 hours of industrial or field use.

AIR CLEANER.

Care of the air cleaner is **EXTREMELY IMPORTANT** – especially when the vehicle is used under dusty conditions. Clean and refill the air cleaner reservoir to the level mark, with oil of the same grade used in the engine, at each engine oil change. When the vehicle is used for field work, clean and change the oil in the cleaner **DAILY** and under dusty conditions **TWICE DAILY**. When cleaning, use a long screw driver or other suitable tool to dislodge dirt sticking to the bottom and sides of the intake passage in the body of the cleaner.

STEERING GEAR.

Check the level of the lubricant in the steering gear housing every 1000 miles. Avoid the use of cup grease, graphite, white lead or heavy solidified oil. Remove the plug in the steering gear housing and use a hand gun to fill the housing slowly.

WATER PUMP – CLUTCH.

The water pump and clutch release bearings are prelubricated at assembly and the lubricant lasts for the life of the bearings.

GENERATOR.

Two oilers are provided, one at each end; three to five drops of engine oil is recommended every 1000 miles. Be sure to slip the commutator end hole cover back in place.

STARTING MOTOR.

The oil hole cover on the commutator (front) end slips to one side; put three to five drops of engine oil in this hole every 1000 miles. Be sure to slip cover back in place.

IGNITION DISTRIBUTOR.

The oiler on the distributor should be lubricated every 1000 miles with several drops of engine oil, Fig. 7, No. 6. Also place one drop of light engine oil on the wick, No. 2 located in the top of the shaft, which is accessible by removing the rotor arm and sparingly apply soft grease on the breaker arm cam No. 4, and a drop of oil on the breaker arm pivot, No. 3. See [PROPER MAINTENANCE](#) for Fig. 7.

SPEEDOMETER AND DRIVE.

Some of the speedometers supplied are equipped with a wick type oiler located on the drive shaft boss directly above the tube and shaft connection to the speedometer head. Lubricate this oiler with a few drops of light oil twice each year. Remove the drive shaft from the tube once each year, clean it thoroughly and lubricate with a good quality light graphite grease.

UNIVERSAL JOINTS (PROPELLER SHAFT).

Every 1000 miles lubricate the propeller shaft universal joints and the slip joints with a good quality lubricant. Lubricate daily for field work.

UNIVERSAL JOINTS (FRONT AXLE SHAFT).

The front axle universal joints are enclosed in the steering knuckle housings, which are filled with lubricant so require no attention other than checking each 1000 miles to be sure the housings are filled to plug level. Once each year or every 300 hours of field work the axle shafts and universal joint assemblies should be removed, thoroughly cleaned and the housings filled with new lubricant.

WHEEL BEARINGS.

Front wheel bearings should be removed, thoroughly cleaned, checked and replaced twice yearly or every 6000 miles. The rear wheel bearings are equipped with hydraulic lubricators. Lubricate them sparingly to guard against surplus oil saturating the brake lining. An oil relief hole at the top of housing, Fig. 32, No. 1, indicates when the bearing is filled with oil.

TRANSMISSION AND TRANSFER CASE.

Drilled passages are provided between the transmission and transfer case housings for circulation of the lubricating oil to provide unit lubrication of the two assemblies. The oil level should be checked each 1000 miles or at each lubrication. Drain and refill at each 6000 miles or 300 hours of field work.

Note: The requirements of these housings are small for economy, therefore, it is very important that the lubrication be changed every 300 hours when the vehicle is used for dusty field work.

FRONT AND REAR DIFFERENTIALS.

The differential gears require extreme pressure lubricant, which is suitable for hypoid gear type axles. The level of the lubricant in these units should be checked every 1000 miles. Do not mix different types of hypoid lubricants. Drain and refill the housings each 6000 miles or twice yearly. Use a light engine or flushing oil to clean out the housings.

Note: Do not use water, steam, kerosene, or gasoline for flushing. If the oil is decomposed, dismantling is necessary.

GOVERNOR.

At each lubrication, check the oil level in the governor housing. Use oil of the same grade used in the engine to maintain the lubricant at filler plug level. Drain and refill the housing at each 300 hours of operation.

POWER TAKE-OFF SHAFT AND PULLEY DRIVE HOUSINGS.

Check the lubricant level at each lubrication job, maintaining the lubricant at filler plug level. Should the power take-off be used frequently, change the lubricant each 300 hours.

[View Lubrication Chart.](#)

[Return to The CJ2A Home Page](#)

CJ2A Operation and Care Manual -- Lubrication Chart

Go to the
CJ2A
Page
Home Page

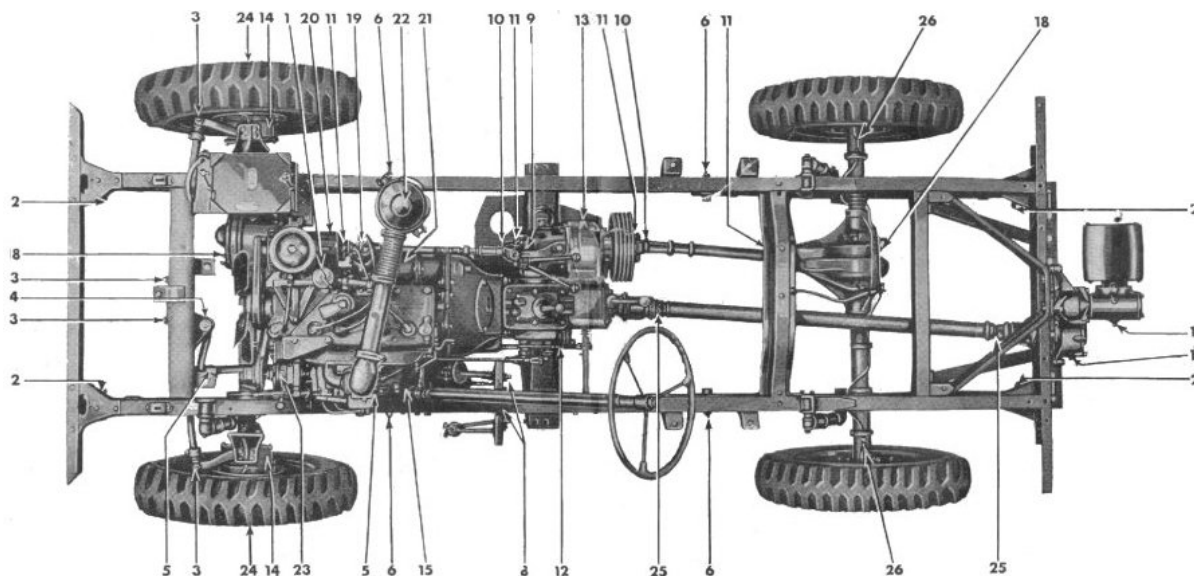

FIG. 17 -- CHASSIS, SHOWING PARTS REQUIRING LUBRICATION

See "[GENERAL LUBRICATION](#)"

Chassis Bearings, Nos. 2, 3, 4, 5, 6, 7, 8, 9, 10, 11

Clean and lubricate each 1000 of road service. Make certain each bearing surface is properly lubricated and oil all clevis pins, yokes, hood hooks and the upper end of the hand brake conduit. Lubricate these parts DAILY when using the vehicle for field work as the new lubricant will force the old from the bearings and the grit and dirt which may have accumulated. Use No. 0 chassis lubricant for winter and No. 1 in summer.

Engine Crankcase, No. 1

Drain engine oil when hot and refill with fresh oil each 2000 miles of road service. For power take-off and field operation change the oil at each 50 hours. Watch the condition of the oil closely and should it be contaminated due to conditions of operation, change it immediately. When changing oil, always drain the oil filter to prevent the dirty oil in the filter from mixing with the new. Change filter unit at each 8000 miles of highway travel and each 200 hours of industrial or field work.

Transmission and Transfer Case, No. 12, 13

Check the level in the housings each 1000 miles. Change oil at each 6000 miles of road service or 300 hours of field work. Note that the requirements of these housings are small for economy and it is important that the oil level be checked regularly and changed at the time specified when the vehicle is used in heavy duty service.

Front and Rear Differentials, No. 18

Check the level at each 1000 miles and change the oil each 6000 miles of road service and 300 hours of field work. Use extreme pressure (hypoid type) lubricant.

Front Axle King Pin Bearings and Universal Joints, No. 14

Check oil level each 1000 miles. Change the lubricant at each 6000 miles of road service and 300 hours of field service.

Steering Gear, No. 15

Check lubricant level each 1000 miles. When level is low use a hand gun to fill the housing slowly. Avoid the use of cup grease, graphite, white lead or heavy solidified oil.

Power Take-Off and Belt Pulley Housings, Nos. 16, 17

Check the lubricant level each time the vehicle is lubricated. Should the units be used frequently change the lubricant each 3000 hours.

Ignition Distributor, No. 19

Lubricate each 1000 miles or equivalent in field service. Place several drops of engine oil in the oiler at the side of housing; also place a drop of light oil on the wick in shaft under the rotor and sparingly apply soft grease on the breaker arm cam and a drop of oil on the breaker arm pivot.

Generator and Starting Motor, Nos. 20, 21

Place three to five drops of oil in the oilers each 1000 miles. Do not overlubricate.

Governor, No. 23

At each lubrication check the level in the housing. note that three plugs are provided; drain plug, level plug and filler plug. Fill the housing to the filler plug level with the same grade oil used in the engine. Avoid overfilling.

Air Cleaner, No. 22

For normal operation clean the air cleaner and replace the oil each 2000 miles using the same grade used in the engine. Clean this unit and change oil in accordance with conditions of operation -- twice daily when the vehicle is used in extremely dusty field service.

Power Take-Off Universal Joints, No. 25

For average service the original factory lubrication will last the life of the vehicle. If the power take-off is used often for continuous operation, disassemble and repack once each year.

Front Wheel Bearings, No. 24

Remove the front wheel bearings and clean them thoroughly each 6000 miles of road service or 300 hours of industrial service after which repack them with wheel bearing lubricant.

Rear Wheel Bearings, No. 26

Lubricate the rear wheel bearings sparingly with a compressor. See WHEEL BEARINGS.

NOTE -- The water pump and clutch release bearings are prelubricated and the lubricant lasts for the life of the bearings. Some of the speedometers supplied are equipped with a wick type oiler located on the drive shaft boss directly above the tube a d shaft connection to the speedometer head. Lubricate this oiler with a few drops of light oil twice each year.

CAUTION -- Do not use mineral oil on the shock absorber rubber mounting connections.

[Return to The CJ2A Home Page](#)

CJ2A Operation and Care Manual -- Proper Maintenance

Go to the
CJ2A
Page
Home Page



NEVER RUN ENGINE IN CLOSED GARAGE

Due to the presence of carbon monoxide (a poisonous gas in the exhaust of the engine) never run the engine for any length of time while the vehicle is in a small closed garage. Opening the doors and windows will lessen the danger considerably, but it is safest if adjustments are being made that require the operation of the engine, to run the vehicle out-of-doors.

INSPECTION.

The old adage "An ounce of prevention is worth a pound of cure" was never more true than when applied to any motor vehicle. The importance of regular systematic inspection cannot be over-emphasized. Small and seemingly unimportant faults, if neglected, may grow into expensive major repairs. Regular inspections and prompt correction of small faults will go far toward holding down maintenance expense, eliminating delays in productive operations and upholding the high standard of reliability and performance built into your "Jeep" at the factory.

ENGINE TUNE-UP.

For best performance and dependability the engine should have a periodic tune-up twice yearly, preferably in the Spring and Fall.

- Remove the spark plugs, clean them thoroughly and space the electrodes to .030" (0.76 mm.) gap.
- Clean and tighten the battery cable terminals, the battery ground connection and the ground strap on the right side of the engine at the front engine support (See Fig. 10).
- Remove the distributor cap and inspect the contact points. Adjust the points to .020" (0.51 mm.) gap. See Fig.7 No.5.
- Check the ignition timing.
- Check the valve tappet clearance. Adjust to .014" (0.356 mm.) clearance with engine hot or cold.
- Clean the fuel pump filter screen and check fuel line connections.
- Remove ventilator valve Fig. 12 and clean.
- Start the engine and allow it to run until thoroughly warm then set the carburetor idle screw so the engine will idle at 600 rpm. (vehicle speed of approximately 6 mph).
- Adjust the carburetor low speed idle screw so that the engine will idle smoothly.

NOTE: Should the engine fail to perform satisfactorily and the trouble is definitely traced to the carburetor, consult your Willys-Overland Dealer. Carburetor service is specialized and should not be undertaken unless the unit is thoroughly understood.

VALVE AND IGNITION TIMING

X
X
Inlet opens 9 degrees before top centre
Inlet closes 50 degrees after bottom centre
Exhaust opens 47 degrees before bottom centre
Exhaust closes 12 degrees after top centre
Spark Setting

Spark set top centre with automatic spark controls at rest, when using low octane fuel.

Firing Order
Tappet setting for valve timing
Number of flywheel teeth

Piston Measurements

From Top Centre
.039" (9.91 mm.)
3.772" (95.81 mm.)
3.799" (96.49 mm.)
.054" (0.14 mm.)
"IGN" 5° BTC
X
X
X
X
1-3-4-2
.020" (0.51 mm.)
97

CHECKING VALVE TIMING

To check the valve timing, adjust the inlet valve tappet No. 1 cylinder to .020" (0.51 mm.). Use care in making this adjustment that the measurement is accurate with feeler gauges and that the tappet is resting against the lowest surface of the camshaft cam. Rotate the crankshaft clockwise until piston in No. 1 cylinder is ready for the intake stroke. (Mark "I-O" -- intake open -- on the flywheel is in the centre of the engine.) With the crankshaft in this position, valve timing is correct if No. 1 intake valve tappet is just tight against the end of the valve stem. After checking, adjust all of the tappets .014" (0.356 mm.).

Should the timing be incorrect it is advisable to consult your Willys-Overland Dealer.

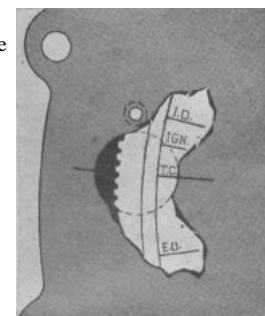

FIG. 6 -- FLYWHEEL
TIMING MARKS

IGNITION TIMING

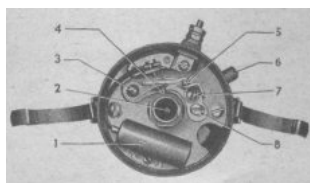

FIG. 7 -- DISTRIBUTOR

1. Condenser
2. Lubricating Wick
3. Breaker Arm Pivot
4. Breaker Cam
5. Distributor Points
6. Oiler
7. Adjustment Lock Screw
8. Adjusting Screw

The breaker points should be cleaned and adjusted to .020" (0.51 mm.) opening. Remove all of the spark plugs except No. 1. Rotate the crankshaft until No. 1 piston is coming up on the compression stroke which can be determined by the resistance in the cylinder. Remove the spark plug and continue to turn the engine slowly until the mark "IGN" on the flywheel is in the centre of the timing hole at the right rear. This places the piston in the correct position to set the ignition.

Loosen the distributor clamp and rotate the distributor assembly until the distributor rotor arm points to No. 1 terminal in the distributor cap and the distributor points just start to break. To advance the timing, turn the distributor in a clockwise direction; to retard it, turn in a counter-clockwise direction. Tighten the clamp screw firmly but do not overtighten it.

The engine firing order is 1-3-4-2.

After setting the timing, revolve the crankshaft two complete turns, to make sure all backlash is eliminated, and check the timing to the flywheel mark "IGN".

Ignition timing must be accurately set to obtain the maximum efficiency of the engine. Information above is given only to enable the operator to place the vehicle back in service should trouble develop. At the first opportunity, have your Willys-Overland Dealer check the setting with a neon timing lamp which can also be used to check the automatic spark advance operation, by accelerating the engine.

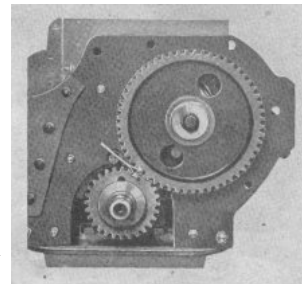

FIG. 8 -- TIMING GEAR MARKS

[Return to The CJ2A Home Page](#)

CJ2A Operation and Care Manual -- Proper Maintenance (part 2 -- Engine Fails to Start, Oil System)



ENGINE FAILS TO START

Should the engine suddenly stop or fail to start, check the cause as follows. Also see [EMERGENCY CHART](#).

- Make sure there is gasoline getting to the carburetor (Note: Should the trouble be traced to the gasoline supply see [FUEL SYSTEM](#)) and that the ignition switch is "ON".
- Check ignition circuit wiring connections to be sure they are tight and clean.
- Check that the distributor breaker points are smooth, have a flat contact with each other and are set to the proper gap (.020"). If the points are rough, replace them or temporarily smooth them with a breaker point file.
- Inspect the distributor cap and rotor for cracks, carbon runners or burned places. If they are found replace the part.
- See that the current is reaching the distributor breaker points. To make this test, turn on the ignition switch, remove the distributor cap and turn the engine until the breaker points are open, then holding one end of a piece of wire on the breaker arm, strike the other end on a clean, unpainted surface of the engine. No flash indicates a poor or open connection between the switch and distributor or an open circuit in the coil. If the wire and connections leading to the coil are in good condition, then an open primary in the coil is apparent and a new coil will be necessary.

If a flash occurs when testing the primary, as outlined above, it indicates that the primary circuit is all right and the trouble is elsewhere so the secondary coil circuit should be tested as follows:

To test the secondary coil circuit, remove the distributor cap and turn the engine until the breaker points are making contact. Turn "ON" the ignition switch and remove the high tension wire (center wire) from the distributor cap. Hold this wire about one-eighth of an inch from a clean, unpainted surface of the engine, then open and close the breaker points with the finger, giving them a short, snappy break. A fat, flame-coloured spark indicates the coil is in good condition. No spark indicates the secondary winding of the coil is open, while a thin, stringy spark indicates an internally shorted coil or a loose or inoperative condenser. Condenser trouble will also be indicated by badly burned breaker points.

Should the test show a thin, stringy spark, check the condenser first. Be sure that the mounting screw is tight and is making a good ground connection to the distributor body and also that the connecting wire to the distributor points is not broken or the connection loose. Should no trouble be found in the condenser mounting or connection, install a new condenser which will localize the difficulty in either the coil or the condenser. No repairs can be made to either the condenser or coil, it being necessary to replace them if inoperative.

MANIFOLD HEAT CONTROL

The manifolding is designed to utilize the exhaust gasses of the engine to provide a quick means of heating the inlet manifold, thereby reducing the length of time the choke must be used after starting a cold engine and making the engine more flexible during the warm up period. The heat control valve, Fig. 9, which controls the amount of exhaust gasses by-passed around the intake manifold insures more complete vaporization of the fuel. This control is fully automatic.

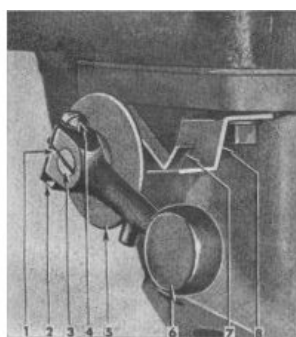

FIG. 9 -- HEAT CONTROL VALVE

1. Heat Control Valve Lever Key
2. Heat Control Valve Lever Clamp Bolt Nut
3. Heat Control Valve Shaft
4. Heat Control Valve Lever Clamp Screw
5. Heat Control Valve Bi-Metal Spring Washer
6. Heat Control Valve Counterweight Lever
7. Heat Control Valve Bi-Metal Spring
8. Heat Control Valve Bi-Metal Spring Stop

The valve shaft should turn freely in the manifold at all times. Note that the thermoplastic spring, No. 7, should be assembled above the metal stop, No. 8.

ENGINE MOUNTINGS

The rubber engine mountings, which are attached to the frame side rail brackets and to the support plate, prevent fore-and-aft motion of the engine, yet allow free sidewise and vertical oscillation which neutralizes vibration at the source. Keep the mountings tight. A loose engine may cause vibration, clutch chatter or high fuel level in the carburetor.



The rubber surface of the mountings partially insulates the engine from the frame. To assure a positive electrical connection between the engine and the frame, a ground strap is provided at the right front engine support under the generator. See Fig. 10. The two attaching screws must be kept tight and the connections clean. A loose or poor connection may result in hard engine starting, low charging rate of the generator or sluggish operation of the starting motor.

OIL PUMP ASSEMBLY

The oil pump assembly is provided with a pressure relief valve which controls the maximum oil pressure at all speeds.

The standard controlled pressure is 35 lbs. at 30 mph. and 10 lbs. at the idle speed of 600 rpm. as registered by the dash gauge. Pressure may be adjusted by installing or removing shims between the relief plunger spring and the spring retainer. Add shims to increase the pressure or remove to decrease.

1. Cover Screw
2. Cover
3. Cover Gasket
4. Outer Rotor
5. Shaft and Rotor
6. Body
7. Driven Gear
8. Gasket
9. Gear Retaining Pin
10. Relief Valve Retainer
11. Relief Valve Retainer Gasket
12. Relief Valve Spring
13. Relief Valve Plunger

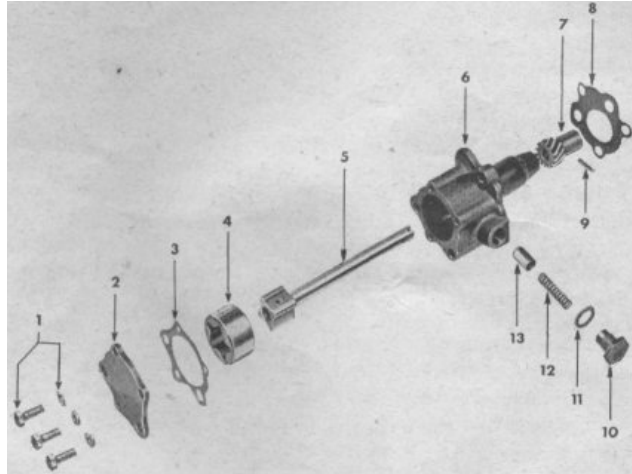

The oil pump drive shaft drives both the pump and the distributor assembly. See Fig. 2. Should it be necessary to remove the oil pump assembly, first remove the distributor cap and carefully note the position of the rotor to allow reinstallation without disturbing the ignition timing. When the pump is installed, use care that the driving key on the end of the distributor shaft is correctly meshed with the slot on the end of the pump shaft. To make the installation without disturbing the ignition timing, the pump gear must be correctly meshed with the camshaft gear to allow mesh of the distributor driving key and slot with the distributor rotor in the original position. Should it be necessary to reset the ignition timing, refer to the [previous page](#).

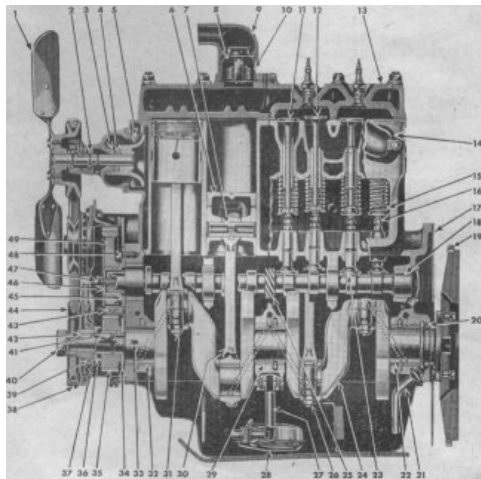

FIG. 2 -- SIDE SECTIONAL VIEW OF ENGINE

- | | |
|---|--|
| 1. Fan Assembly | 26. Connecting Rod Cap Bolt |
| 2. Water Pump Bearing and Shaft Assembly | 27. Oil Float Support |
| 3. Water Pump Seal Washer | 28. Oil Float Assembly |
| 4. Water Pump Seal Assembly | 29. Crankshaft Bearing Centre - Lower |
| 5. Water Pump Impeller | 30. Connecting Rod Assembly - No. 2 |
| 6. Piston | 31. Connecting Rod Bolt Nut Lock |
| 7. Wrist Pin | 32. Crankshaft Bearing - Lower Front |
| 8. Thermostat Assembly | 33. Crankshaft Oil Passages |
| 9. Water Outlet Elbow | 34. Crankshaft Thrust Washer |
| 10. Thermostat Retainer | 35. Crankshaft Gear |
| 11. Exhaust Valve | 36. Crankshaft Gear Spacer |
| 12. Intake Valve | 37. Timing Gear Cover Assembly |
| 13. Cylinder Head | 38. Fan and Governor Drive Belt |
| 14. Exhaust Manifold Assembly | 39. Crankshaft Oil Seal |
| 15. Valve Spring | 40. Starting Crank Nut Assembly |
| 16. Valve Tappet Self-Locking Adjusting Screw | 41. Crankshaft Carrier Key |
| 17. Engine Plate - Rear | 42. Fan and Governor Drive Pulley Key |
| 18. Camshaft | 43. Timing Gear Oil Jet |
| 19. Flywheel Ring Gear | 44. Fan, Generator and Governor Drive Pulley |
| 20. Crankshaft Packing - Rear End | 45. Camshaft Thrust Plate |
| 21. Crankshaft Bearing Rear Drain Pipe | 46. Camshaft Gear Retaining Washer |
| 22. Crankshaft Bearing Rear - Lower | 47. Camshaft Gear Retaining Screw |
| 23. Valve Tappet | 48. Camshaft Gear Thrust Plate Retaining Screw |
| 24. Crankshaft | 49. Camshaft Gear |
| 25. Oil Pump and Distributor Drive Gear. | |

FLOATING OIL INTAKE

The floating oil intake (No. 28, Fig. 2) is attached to the crankcase with two screws. The construction of the float and screen cause it to remain on top of the oil, preventing the circulation of water and dirt.



Once each year remove the float, screen and tube and clean thoroughly with a suitable cleaning fluid. When replacing, place some sealer on the gasket where the tube bears against the engine crankcase. A leak at this point will allow air to enter the oil suction line seriously affecting oil pressure.

CRANKCASE VENTILATOR

The crankcase ventilating system provides thorough, positive ventilation which reduces to a minimum the formation of sludge. In operation (see Fgi. 12) clean air flows from the air cleaner through the short connecting tube to the oil filler tube and then through the crankcase and valve compartment to the intake manifold. Any vapours in the crankcase are carried into the manifold and burned. Positive air circulation reduces oil temperatures and the formation of moisture due to condensation. Air flow is controlled at the manifold by the control valve.

Be sure there are no air leaks at the tube connection between the air cleaner and oil filler tube, and that the oil filler tube cap gasket is in good condition. Always keep the cap locked securely in place.

When tuning the engine of grinding valves, remove the control valve and clean it thoroughly. If this valve is blocked with carbon, the ventilating system will not operate and should the valve fail to seat, it will be impossible to make the engine idle satisfactorily.

[Return to The CJ2A Home Page](#)

CJ2A Operation and Care Manual -- Proper Maintenance (part 3 -- Engine Electricals, Fuel and Cooling Systems.)

Go to the
CJ2A
Page
Home Page



GENERATOR

The generator is a 35-ampere, two-brush unit which does not require adjustment to increase or decrease output. This is accomplished by the regulator which limits the current generated to that which is required by the battery. The generator charging rate, as shown by the ammeter, will be low when the battery is well charged and correspondingly higher as charging is required.

As a general rule it will not pay an owner, not equipped with specialized test equipment, to undertake generator repairs. There are some adjustments which may be made without this equipment and which are covered below.

Should the generator stop charging, examine all connections in the charging line to be sure they are clean and tight. Also note the condition of the commutator and brushes. If the commutator is dirty and discoloured, it can be cleaned by holding a piece of No. 00 sand-paper against it with the engine running at idle speed. Do not use emery or carborundum cloth.

The brushes must slide freely in their holders and should they be badly worn or oil soaked, they should be replaced. Excessive arcing between the commutator and brushes usually indicates incorrect seating of the brushes against the commutator or high mica insulation between the commutator segments. Incorrect seating may be corrected by drawing a piece of No. 00 sand-paper around the commutator with the sanded side against the brush. After sanding, blow the carbon dust and sand from the generator.

Should the above attention fail to make the unit operate satisfactorily, consult your Willys-Overland Dealer.

VOLTAGE REGULATOR

The regulator must be adjusted with great accuracy; hear as well as voltage and amperage must be considered when adjusting it. Should trouble develop in the regulator either consult a Willys-Overland Dealer or install a new one.

DISTRIBUTOR ASSEMBLY

The distributor delivers the spark to the right cylinder at the right time. The mechanical breaker, built into the distributor, opens and closes the primary circuit at the exact time for ignition. See Fig. 7 on the first page of [Proper Maintenance](#).

The distributor cap should be kept clean for efficient operation. It should be inspected periodically for cracks, carbon runners, evidence of arcing and badly corroded high tension terminals. If any of these conditions exist, the cap should be replaced.

Inspect the distributor rotor for cracks or evidence of excessive burning at the end of the metal strip. After a rotor has had normal use, the end of the metal strip will become burned. If burning is found on top of the rotor, it indicates the rotor is too short and should be replaced. Usually then this condition is found, the distributor cap segment will be burned on the horizontal face and the cap should also be replaced.

The distributor contact points should be kept clean and not burned or pitted. The contact gap should be set at .020" (0.51 mm.). When making adjustments, be sure that the fibre block in the breaker arm rests on one of the high points of the cam. Adjust the points by loosening the lock screw and turning the eccentric head screw. Recheck the gap after tightening the lock screw.

Should new contact points be installed they should be aligned so as to make contact at the centre of the contact surfaces. Bend the stationary contact bracket to secure correct alignment and then recheck the gap.

SPARK PLUGS

Keep spark plug porcelains clean. Dirty porcelains will cause hard engine starting and poor operation especially in damp weather.

The spark plug electrode gap should be set at .030" (0.76 mm.). Too wide gap will cause misfiring, especially at high speeds and when operating with open throttle, while a small gap causes poor idling. Uniform gap setting assures smooth engine operation.

It is recommended that spark plugs be replaced at intervals of each 10,000 miles of service for, because of erosion, the spark loses intensity.

STARTING MOTOR

The starting motor requires little attention except regular lubrication. It is a standard three-bushing type motor with right-hand type Bendix spring.

It is not advisable to lubricate the Bendix drive shaft. In use dirt and dust will cling to the Bendix shaft, if lubricated. In time the shaft may become gummy, preventing engagement of the Bendix pinion with the fly-wheel ring gear, especially in cold weather. Should the starting motor turn without turning the engine, remove the motor and wash the Bendix assembly thoroughly with cleaning solution.

FUEL SYSTEM

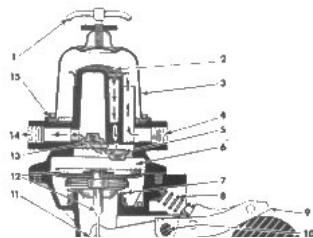

The fuel system consists of the fuel tank lines, fuel pump, carburetor and air cleaner. The most important maintenance attention is to keep the system clean and free of water, also periodically inspect for leaks. Should the vehicle be stored for an extended period, the fuel system should be completely drained and the engine started and allowed to run until the carburetor is emptied. This will avoid oxidation of the fuel, resulting in the formation of gum in the units of the system.

Gum formation is similar to hard varnish and may cause trouble in the fuel pump valves or the carburetor float valve may become stuck or the filter screen blocked. Gum formation can be dissolved by acetone, obtainable in

most drug stores. In extreme cases, it will be necessary to disassemble and clean the fuel system, however, often one pint of acetone placed in the fuel tank with about one gallon of gasoline will dissolve any deposits as it passes through the system with the gasoline.

CARBURETOR

The Carter carburetor, Model W.O.-596S is a precision instrument designed to deliver the proper fuel and air mixtures at all engine speeds. Carburetor parts wear little; the chief cause of faulty carburetor is blamed for poor engine performance when the trouble is elsewhere (see [EMERGENCY CHART](#)). Do not disturb the carburetor until it is proven that the trouble is not elsewhere. Should it be determined that the carburetor is at fault consult your Willys-Overland Dealer.

The carburetor is provided with an external adjustment to secure smooth engine idle. Fig. 14, No. 15. To set this adjustment, proceed as follows:

Make sure that the choke is in a fully open position. Close the idle adjustment by turning it to the right or in against the seat; then open it one and one-quarter turns. Start the engine and run it until operating temperature is obtained, then turn the adjustment in or out slightly until the engine fires evenly. Open the throttle for a few seconds allowing the engine to clean the manifold. Recheck the adjustment, then set the throttle stop screw at an idle speed of 600 rpm. or approximately 6 miles per hour in high gear.

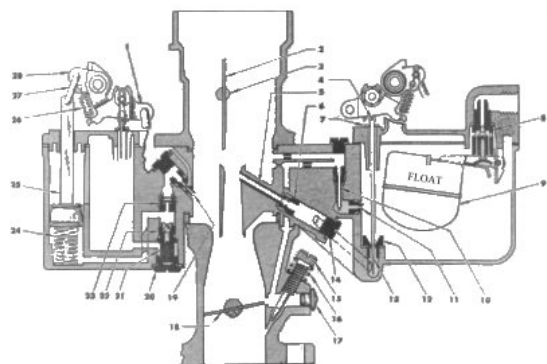

- | | |
|---|-----------------------------------|
| 1. Pump Operating Lever Assembly | 15. Idle Adjustment Screw |
| 2. Choke Valve Assembly | 16. Idle Adjustment Screw Spring |
| 3. Choke Shaft and Lever Assembly | 17. Idle Port Rivet Spring |
| 4. Metering Rod Spring | 18. Throttle Valve |
| 5. Nozzle | 19. Pump Jet |
| 6. Nozzle, Retaining Plug | 20. Pump Jet Strainer Nut |
| 7. Metering Rod Disc | 21. Pump Jet Strainer |
| 8. Needle, Pin, Spring and Seat Assembly | 22. Intake Ball Check Assembly |
| 9. Float and Lever Assembly | 23. Discharge Disc Check Assembly |
| 10. Low Speed Jet Assembly | 24. Pump Plunger Spring |
| 11. Idle Well Jet | 25. Pump Plunger and Rod Assembly |
| 12. Metering Rod Jet and Gasket Assembly | 26. Pump Arm Spring |
| 13. Metering Rod | 27. Pump Connecting Link |
| 14. Nozzle Passage Plug and Gasket Assembly | 28. Pump Arm and Collar Assembly |

FIG. 14 CARBURETOR

FUEL DIFFUSER

The engine is equipped with a fuel diffuser built as part of a thick insulating gasket which is installed between the carburetor and the intake manifold. In operation the diffuser causes intense swirling of the fuel and air in the manifold. Under some operating conditions this results in a drier and more satisfactory fuel mixture.

FUEL PUMP

The fuel pump is of the diaphragm type attached to the left side of the crankcase and operated from an eccentric on the camshaft, Fig. 13. The pump draws gasoline from the fuel tank, through a filtering screen mounted in the pump sediment chamber and forces it to the carburetor. The pump pressure is 4 ½ lbs. at 16" above the outlet at 1800 rpm. Engine speed.

The sediment chamber can be removed by backing off the thumbscrew nut sufficiently to permit swinging the wire clamp to one side. The bowl or cover should be washed and wiped dry and the screen dried and then cleaned with a stiff brush. When reassembling the bowl, make certain that the cork gasket is not broken; reverse it and position it flat on the seat then install the bowl and tighten the thumb nut securely. After cleaning, start the engine and carefully inspect the bowl to guard against leakage.

Lack of gasoline in the carburetor may be caused by the following conditions:

- Gasoline tank empty.
- Leaking tubing or connections.
- Bent or kinked tubing.
- Clogged fuel lines – (or frozen).
- Sediment bowl on fuel pump loose.
- Dirty screen.
- Carburetor inlet valve stuck shut.

Should the carburetor flood (too much gasoline), check the unit to make certain that the needle valve Fig. 14, No. 8, is seating properly and that the float No. 9 is not stuck.

CAUTION: Do not attempt repairs which require disassembling of the fuel pump other than cleaning as special care is required. It is recommended that all fuel pump trouble be taken up with your Willys-Overland Dealer.

FUEL SUPPLY TANK

The capacity of the fuel tank is 10 ½ gal. (U.S.). When filling the tank, care should be used that no foreign matter or water enters the tank. Once each season, at a time when the fuel supply is low in the tank, remove the drain plug in the bottom to drain out sediment and water which may have accumulated.

COOLING SYSTEM

The practice of checking the condition of the cooling system of your Jeep while lubricating it will guard against costly delays in service. Inspecting the condition of the radiator and heater hoses; also the fan belt and water pump will eliminate the possibility of an overheated engine due to a water leak or loose fan belt.

RADIATOR ASSEMBLY

The radiator is designed to cool the water under all operating conditions however, the core must be kept free from corrosion and scale and the air passages free of chaff, dust and mud.

At least twice a year flush out the cooling system. A good way to do this is to remove the drain cock at the bottom of the radiator and that in the cylinder block under the generator. Place a hose in the radiator filler opening and adjust the flow of water to equal that draining from the two openings. Start the engine and allow it to run until the cooling system is thoroughly flushed. After flushing it is advisable to install a corrosion inhibitor in the system to prevent rust and scale. This may be obtained from your Willys-Overland Dealer.

Should the air passages become clogged, do not use a metal tool of any kind to clean them. Use compressed air or water pressure and clean from the rear, forcing the dirt out through the front of the radiator.

RADIATOR FILLER CAP

The cap is of the pressure type, which prevents evaporation and loss of cooling solution. A pressure up to 4 ½ pounds makes the engine more efficient by permitting a slightly higher operating temperature. Vacuum in the radiator is relieved by a valve in the cap which opens at ½ to 1 pound vacuum.

DRAINING COOLING SYSTEM

To completely drain the cooling system, open both drain cocks; that at the bottom of the radiator and *also in the cylinder block under the generator*. Remove the radiator cap to break any vacuum which might prevent thorough draining.

THERMOSTAT

A 145° to 155° F. thermostat, Fig. 2, is used to provide quick warming and to prevent overcooling during normal vehicle operation. The temperature at which this unit operates is set by the Manufacturer and can not be altered. The thermostat should be checked first, should sudden overheating occur, as failure to operate will nearly block the water circulation. As a check, remove the thermostat and if the overheating is eliminated, install a new one.

HEAT INDICATOR

The heat indicator is of the hydraulic type and is connected to a bulb mounted in the water chamber of the cylinder head, by a capillary tube. Should this unit fail to operate, it should be replaced as it is not practical to either repair or adjust it.

WATER PUMP

The water pump assembly Fig. 15 is a centrifugal impeller type, of large capacity to circulate the water in the entire cooling system.

The sealed type double-row ball bearing is integral with the shaft and is packed at the time of assembly with a special high melting point grease, so requires no lubrication.

FAN BELT

The fan and generator are driven by a "V"-type belt. The drive is on the sides of the belt, therefore it is not necessary to adjust it tight, which might cause excessive wear on the water pump and generator bearings. Adjust the belt by swinging the generator away from the engine until the belt can be depressed 1" by thumb pressure midway between the pulleys.

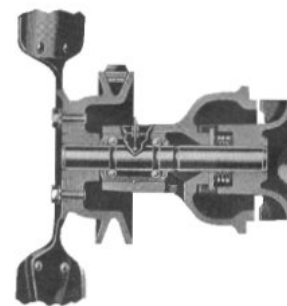

FIG. 15 -- WATER PUMP ASSEMBLY

[Return to The CJ2A Home Page](#)

CJ2A Operation and Care Manual -- Proper Maintenance (part 4 -- Electrical System)

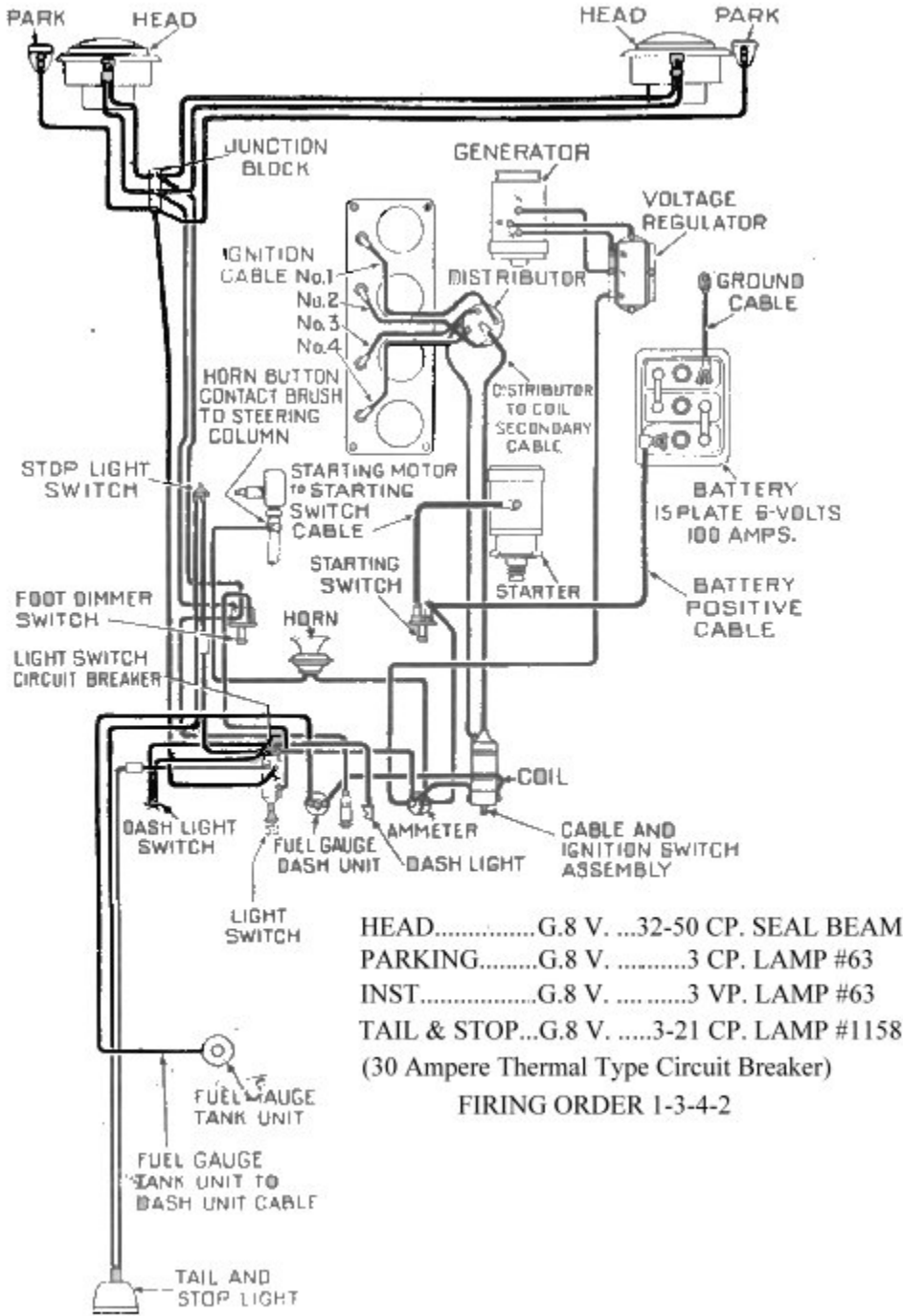

FIG. 16 -- WIRING DIAGRAM

ELECTRICAL SYSTEM

The wiring diagram (Fig. 16) shows the general arrangement of all of the electrical circuits, together with all the units in correct relation to the position in which they are found. Regular inspection of all electrical connections avoids failures in the electrical system. When tracing any one particular circuit, note that the wires have different coloured tracers to identify each individual wire.

BATTERY

The battery is of 6-volt, 15-plate, 100-ampere hour capacity. It is located under the hood on a bracket attached to the right hand side rail of the frame and held firmly on the base with a hold-down frame and two studs and wing nuts.

Check the battery once a week with a hydrometer and at the same time check the electrolyte level in each cell; add distilled water to maintain the solution level 5/8" (9.52 mm.) above the plates. Avoid overfilling and do not fail to replace the filler caps and tighten securely. If the plates are exposed for any length of time, they can be seriously damaged, therefore, it is

important to add enough water to keep the plates covered.

A hydrometer reading of 1.285 to 1.300 indicates that the battery is fully charged. Should the reading fall below 1.225, it will be necessary to recharge the battery or else use lights and the battery sparingly until the battery has had an opportunity to build itself up again.

Coating the battery terminals with a light grease will protect them from corrosion. The battery must be held securely in place, otherwise it may shift, resulting in loose connections, broken cells or other trouble.

Should a sufficiently charged battery fail to crank the engine, it is probably due to loose or corroded terminals or ground connections. The terminal connections should be removed and all corrosion cleaned from them, as well as the posts, to insure proper contact. Clean and tighten the grounded connection on the frame. Clean and tighten the engine ground cable located on the right hand side of the engine Fig. 10. This connection is necessary, due to the rubber engine mountings.

FUEL GAUGE

The fuel gauge circuit is composed of the indicating unit, mounted on the instrument panel, and the fuel tank unit, connected by a single wire through the ignition switch.

Should the gauge fail to register, check all wire connections to be sure they are tight and clean; also be sure both units are well grounded. If, after this check, the gauge does not indicate properly, remove the wire from the tank unit and connect it to a new tank unit which must be grounded to the tank or frame for test. Turn the ignition switch "ON" and move the float arm through its range of travel, watching the dash unit to determine if it indicates correctly. If it fails to do so, the trouble is probably in the dash unit and it should be replaced.

Should a new tank unit be unavailable for this test, disconnect the tank unit wire at the instrument panel gauge. Connect one lead of a 6v., 1 CP test light to the instrument panel unit terminal and with the ignition switch "ON" ground the other. If the unit is operating correctly the pointer will move approximately three-quarters across the dial.

Do not attempt to repair wither unit; replacement is the only procedure.

LIGHTING SYSTEM

The wiring of the lighting system is shown in Fig. 16. The lighting circuit is protected by an overload circuit breaker mounted on the back of the main light switch and no replaceable fuse is required. It clicks off and on in the event of a short circuit in the wiring. The upper and lower headlight beams are controlled by a foot switch located on the toe board at the left of the clutch pedal.

MAIN LIGHT SWITCH

The main light switch Fig. 18 has three positions. When the switch control knob is all the way in, all lights are turned off. Pulling it out to the first position turns on the parking lights; all out to the second position, the driving lights.

Should it be necessary to install a new light switch, refer to the wiring diagram, which indicates the correct wires to install on the several terminals. To remove the switch, loosen the set screw in the side of the switch control knob and remove the knob by unscrewing. The retaining nut may then be removed and the switch removed through the rear of the instrument panel.

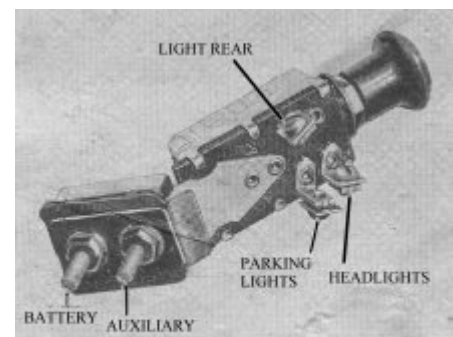

FIG. 18 -- MAIN LIGHT SWITCH

STOPLIGHT SWITCH

The stoplight switch is of the diaphragm type and is located in the front end of the brake master cylinder. When the switch becomes inoperative, it is necessary to install a new one.

HEADLAMP AIMING

Headlamps may be aimed correctly by using an aiming screen or wall, Fig. 19, providing a clear, level space of 25 feet from the front of the headlights to the screen or wall is available.

The screen should be made of light coloured material and should have a black centre line for use in centering the screen with the vehicle. The screen should also have two black vertical lines, one on each side of the centre line at a distance equal to the lamp centres.

Place the vehicle on the floor with the tires inflated to the recommended pressure for highway use. Set the vehicle 25 feet from the front of the screen or wall so that the centre line of the vehicle is in line with the centre line on the screen. To position the vehicle, stand at the rear and sight through the windshield down across the cowl and hood. Measure from the floor to the centre of the headlamp and mark a horizontal line on the screen 3 inches less. Turn on the headlamp upper beam, cover one lamp and check the location of the beam on the screen. The centre of the "hot spot" should be centred on the intersection of the vertical and horizontal lines. If the aim is incorrect, remove the headlamp door screw and remove the door, then adjust the two screws in the mounting ring and move the headlamp unit until the beam is correctly aimed, then tighten. Cover the headlamp aimed and adjust the other in the same manner.

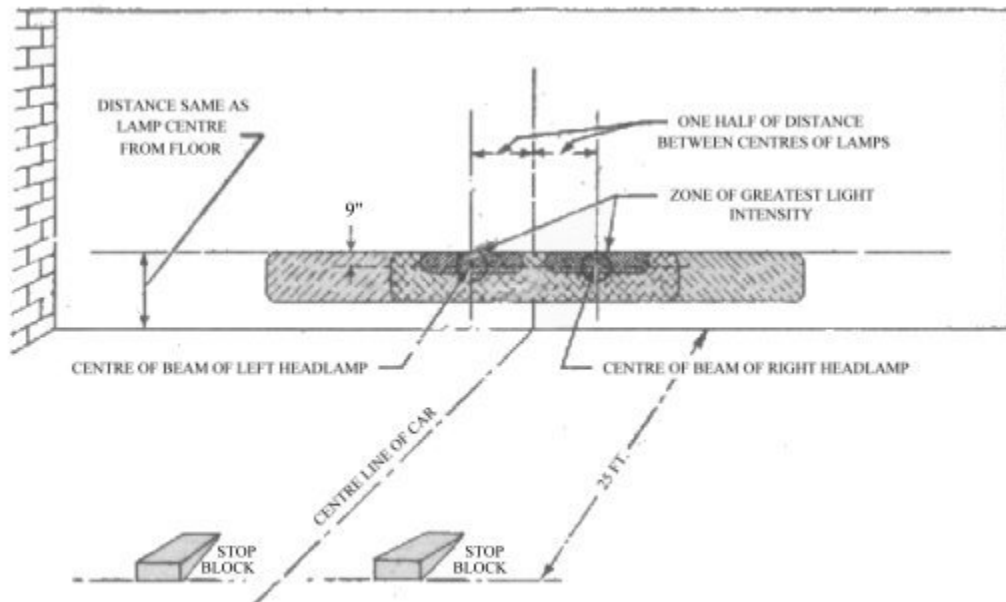

FIG. 19 -- HEADLIGHT AIMING CHART

[Return to The CJ2A Home Page](#)

CJ2A Operation and Care Manual -- Proper Maintenance (part 5 -- Transmission and Axles)

Go to the
CJ2A
Page
Home Page



CLUTCH

The clutch is of the single, dry plate type consisting of a pressure plate assembly, having three pressure springs, three release levers; and a spring cushioned, faced driving plate mounted on a hardened steel, splined hub. Clutch release is accomplished by moving the release bearing toward the flywheel. The three springs located in the clutch bracket provide the driving pressure, thus, when the foot pressure is removed from the pedal, the springs force the pressure plate forward against the driven plate, gradually and smoothly applying power to the wheels.

As the clutch facings wear, the clearance between the release levers and the release bearing is decreased. The effect on the clutch pedal is to decrease the free travel, which is the distance the pedal moves away from the toe board before the release bearing comes into contact with the release levers. Adjusting the length of the clutch control cable to increase the free travel of the clutch pedal, restores the proper clearance between the release levers and the release bearing. See Fig. 20.

The release bearing and clutch pedal must be in their proper positions. No adjustment of the clutch proper is required to compensate for wear of the facings, but a clearance of approximately 1/8" (3.12 mm.) should be maintained between the release levers Fig. 21, No. 14 and the release bearing No. 7. To obtain this clearance, adjust the length of the clutch control cable No. 18, so that the pedal has 1" (25.40 mm.) free movement from the fully engaged position before any resistance can be felt.

CAUTION: Avoid the practice of resting the foot continuously on the clutch pedal while driving and do not slip the clutch excessively instead of shifting gears. Slipping the clutch causes excessive heat, with the result that the clutch is finally made inoperative.

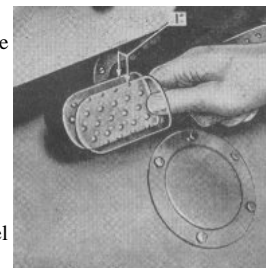

FIG. 20 -- CLUTCH PEDAL
ADJUSTMENT

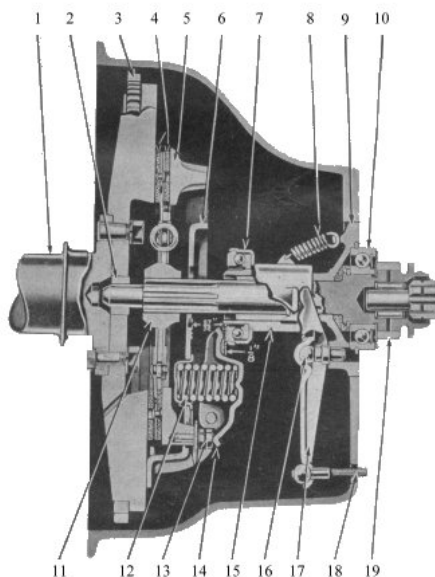

FIG. 21 -- CLUTCH ASSEMBLY

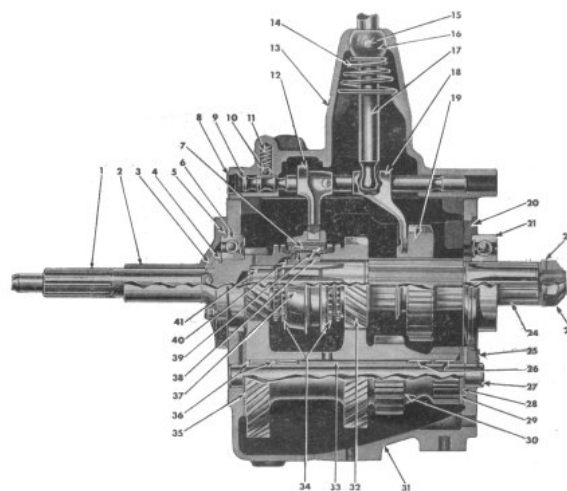

FIG. 22 -- TRANSMISSION

1. Crankshaft
2. Clutch Shaft Bearing
3. Flywheel Ring Gear
4. Clutch Facings
5. Clutch Pressure Plate
6. Clutch Pressure Plate Bracket
7. Clutch Release Bearing
8. Clutch Release Bearing Spring
9. Transmission Main Drive Gear Bearing Retainer
10. Transmission Main Drive Gear Bearing
11. Clutch Driven Plate and Hub
12. Clutch Pressure Spring
13. Clutch Adjusting Screw
14. Clutch Lever
15. Clutch Release Bearing Carrier
16. Clutch Control Lever Fulcrum
17. Clutch Control Lever
18. Transmission Main Drive Gear

1. Main Drive Gear
2. Main Drive Gear Bearing Retainer
3. Main Drive Gear Bearing Retainer Oil Seal
4. Main Drive Gear Snap Ring
5. Main Drive Gear Bearing Snap Ring
6. Main Drive Gear Bearing
7. Synchronizer Shifting Plate
8. Shift Rail Cap
9. Shift Rail -- High and Intermediate
10. Shift Rail Poppet Ball
11. Shift Rail Poppet Spring
12. Shift Fork -- High and Intermediate
13. Control Housing
14. Control lever Support Spring
15. Control Lever Housing Pin
16. Control Lever Fulcrum Ball
17. Gear Shift Lever
18. Shift Fork -- Low and Reverse
19. Sliding Gear -- Low and Reverse
20. Main Shaft Bearing Adapter
21. Main Shaft Bearing

24. Main Shaft
25. Idler and Countershaft Lock Plate
26. Countershaft Gear Bearing Rollers
27. Countershaft Thrust Washer Rear -- Steel
28. Countershaft
29. Countershaft Thrust Washer Rear -- Bronze
30. Countershaft Gears
31. Transmission Case
32. Main Shaft Second Speed Gear
33. Crankshaft Bearing Spacer
34. Synchronizer Blocking Ring
35. Countershaft Thrust Washer Front -- Bronze
36. Countershaft Bearing Washer
37. Intermediate and High Speed Clutch Sleeve
38. Intermediate and High Clutch Hub
39. Synchronizer Ring
40. intermediate and High Clutch Hub Snap Ring
41. Main Shaft Pilot Bearing Roller

- 22. Main Shaft Washer
- 23. Main Shaft Nut

TRANSMISSION ASSEMBLY

The transmission is a heavy duty, three speed synchromesh type unit with cane type shift. It is attached to the rear face of the flywheel bell housing and is supported on a rubber insulator at the frame centre cross member which forms the rear engine support. Shift is smooth and positive through a cane type control lever mounted in a shift housing at the top of the assembly. Poppet balls and springs retain the gears in mesh and an interlock prevents shifting into two gears at one time. Should any trouble be experienced with the transmission assembly, consult your Willys-Overland Dealer.

TRANSFER CASE ASSEMBLY

The transfer case Fig. 23 is an auxiliary unit located at the rear of the transmission. It is essentially a two speed transmission, which provides a low and direct gear, also a means of connecting the drive to the front axle. The shifting mechanism is located on the transfer case for engaging and disengaging the drive to the front axle, also for shifting the gears.

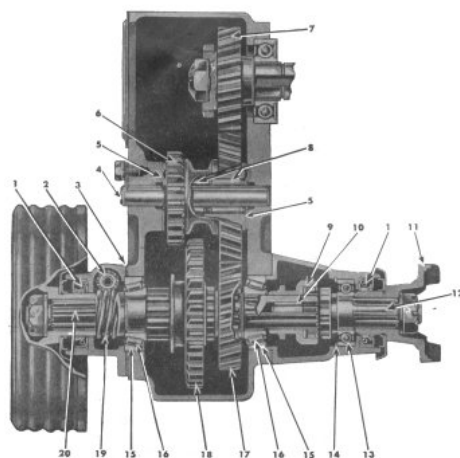

FIG. 23 -- TRANSFER CASE

- 1. Output Shaft Oil Seal
- 2. Speedometer Driven Pinion
- 3. Output Shaft Bearing Shims
- 4. Intermediate Shaft
- 5. Intermediate Gear Thrust Washer
- 6. Intermediate Gear
- 7. Main Shaft Gear
- 8. Intermediate Gear Bearing
- 9. Output Shaft Clutch Gear
- 10. Output Clutch Shaft Pilot Bushing.
- 11. Companion Flange Assembly – Front
- 12. Output Clutch Shaft
- 13. Output Clutch Shaft Bearing
- 14. Output Clutch Shaft Bearing Snap Ring
- 15. Output Shaft Bearing Cap
- 16. Output Shaft Bearing Cone and Roller
- 17. Output Shaft Gear
- 18. Output Shaft Sliding Gear
- 19. Speedometer Drive Gear
- 20. Output Shaft

On hard surface and level roads, disengage the front axle by placing the transfer case shift lever in the forward position. See Fig. 3 in [GETTING STARTED](#). The right hand lever controls the gear ratio; low and high. The low gear can only be engaged when the left hand lever is in the engaged (rear) position for front drive. Proper position for disengaging axles to use the power take-off with the vehicle standing is shown as "N" in Fig. 3 in [GETTING STARTED](#).

Both the transmission and the transfer case are precision built units. No external adjustments are possible and should attention be necessary, it is advisable to consult your Willys-Overland Dealer.

IMPORTANT: Check the units at each lubrication to guard against lubricant leakage. For economy the capacity is small – change the lubricant in accordance with instructions in [GENERAL LUBRICATION](#).

PROPELLER SHAFT

The drive from the transfer case to the front and rear axles is completed through two propeller shafts each equipped with two universal joints. The splined slip joints at the transfer case end of each shaft allows for variations in distance between the transfer case and the axles, due to spring action.

Examine both propeller shafts periodically for foreign matter which may become wrapped around them. Check for dents or a bent shaft and make sure that the universal joints attaching bolts are tight at all times. The universal joints have needle type bearings and are so designed that correct assembly is very simple. No hand fitting or special tools are required. The journal trunnions and needle bearing assemblies are the only parts subject to wear, and when it becomes necessary to replace these parts, the propeller shafts should be removed from the vehicle to facilitate replacement.



FIG. 24 -- ARROW MARKING

When reinstalling, note that the slip joints are marked with arrows, Fig. 24, at the spline and the sleeve yoke. Align the arrows so the yokes of the universal joints at the front and rear of each shaft are in the same plane, when assembled, to avoid vibration. The "U" type attaching bolt nuts should be tightened evenly with approximately the same pressure on each nut.

FRONT AXLE

The front axle is a live driving unit with hypoid drive gears, Fig. 26, and spherical steering knuckles, Fig. 25, containing constant velocity type axle shaft universal joints.

- | | |
|---|---|
| 1. Cap, Wheel Hub -- Left or Right | 13. Oil Seal, Steering Knuckle, Assembly |
| 2. Cap Screw | 14. Universal Joint Assembly, Front Axle |
| 3. Shim Pack, Adjusting, Front Axle Universal Joint | 15. Bushing, Axle Shaft, Front |
| 4. Cone and Rollers, Wheel Bearings | 16. Shim Pack, Adjusting, King Pin Bearing -- Top or Bottom |
| 5. Spindle, Front Wheel | 17. Pin, Lock, King Pin |
| 6. Brake Drum | 18. Pin, Brake Shoe Anchor |
| 7. Brake Cylinder Assembly -- Front | 19. Brake Shoe and Lining -- Front |
| 8. Plate, Backing, Front and Rear Brake Assembly | 20. Oil Seal Assembly, Hub |

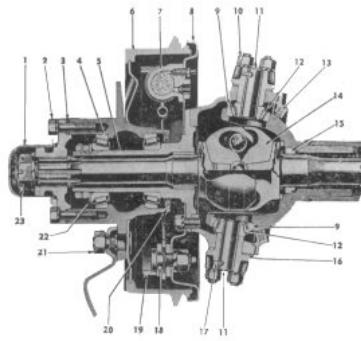

FIG. 25 FRONT STEERING KNUCKLE

9. Cup, King Pin Bearing
10. Nut
11. Pin, King
12. Cone and Rollers, King Pin Bearings

21. Wheel Hub Bolt Nut -- L.H. and R.H. Thread
22. Cup, Wheel Bearing -- Inner or Outer -- Front and Rear
23. Nut, Axle Shaft

1. Hypoid Bevel Drive Gear and Pinion Set (Matched)
2. Drive Pinion Oil Seal
3. Universal Joint End Yoke Assembly
4. Drive Pinion Nut
5. Pinion Shaft Bearing Cone and Rollers (Outer)
6. Pinion Shaft Bearing Cup
7. Pinion Bearing Adjusting Shims (Front and Rear)
8. Drive Pinion Bearing Cone and Rollers (Rear)
9. Drive Pinion Bearing Cup (Rear)
10. Differential Bevel Pinion Mate Shaft Lock Pin
11. Differential Adjusting Shims
12. Differential Bearing Cone and Rollers.
13. Differential Bearing Cup
14. Oil Seal Differential End
15. Axle Shaft (Left)
16. Gear Cover Screw Lockwasher
17. Gear Cover Screw
18. Differential Bevel Side Gear
19. Differential Pinion Mate
20. Differential Bevel Pinion Mate Shaft
21. Gear Carrier Cover
22. Differential Case
23. Gear Carrier Cover Gasket
24. Axle Shaft (Right)
25. Hypoid Bevel Drive Gear Screw
26. Drive Gear Screw Locking Strap

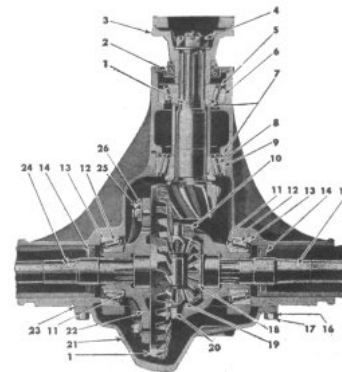

FIG. 26 -- FRONT AXLE DIFFERENTIAL

The differential is mounted in a housing similar to that used in the rear axle, except that the drive pinion shaft is toward the rear of the front and to the right of the centre of the axle. This design allows placing the front propeller shaft along the right side of the engine oil pan without reducing the road clearance under the engine. The axle is of the full floating type and the axle shafts can be removed without dismantling the steering knuckles.

Once each year have your Willys-Overland Dealer remove the front axle universal joint and shaft assemblies to thoroughly wash out the steering knuckle housings and check the shim adjustment of the universal joints. After checking, the universal joint housings must be refilled with good quality lubricant as specified in the [LUBRICATION](#) section.

The lubricant is retained in the steering knuckle housings by felt oil seals mounted in twin retainers attached to the inner face of the housings, Fig. 5 in the [GETTING STARTED](#) section. These seals also prevent dirt and grit entering the housings. Inspect the seals regularly and replace them promptly if damaged.

Keep the spring loaded air vent or breather, mounted in the center housing cover, free of dirt at all times.

REAR AXLE

The rear axle is the semi-floating type, Fig. 27. End float of the axle shafts is adjusted by the shims placed between the brake backing plate and the axle flange.

To remove a shaft for reshimming or replacement, first remove the hub cap and bend back the tongues on the shaft lock nut. Use a wheel puller to remove the wheel hub. Remove the bolts holding the brake dust shield, the grease and bearing retainer and the brake assembly. Also remove the shield and retainer. Pull out the shaft, using care not to lose the bearing adjustment shims. Should the end of a broken shaft be inside the axle housing tube, the broken end can usually be removed by making a loop in a piece of wire and working the loop over the end of the shaft using the wire to pull it from the housing. When the shaft is replaced, adjust the bearing with the shims to allow proper end play of the shaft. See "Rear Wheel Bearings" in the [SUSPENSION](#) section.

1. Wheel Hub Cap, Left or Right
2. Axle Shaft Nut
3. Wheel Hub
4. Brake Drum
5. Brake Cylinder Assembly, Rear
6. Backing Plate, Front and Rear Brake Assembly
7. Brake Cylinder Bleeder Screw
8. Brake Hose Connection
9. Axle Shaft Grease Retainer, Outer
10. Cone and Rollers, Axle Shaft Bearing
11. Axle Shaft, Left
12. Differential Bearing, Cone and Roller
21. Drive Pinion Bearing Cup, Front
22. Drive Pinion Bearing Cup, Rear
23. Drive Pinion Bearing Cone and Rollers, Rear
24. Differential Bevel Pinion Mate Shaft Lock Pin
25. Axle Shaft, Right
26. Differential Bevel Side Gear
27. Differential Oil Filler Plug
28. Differential Bevel Pinion Mate
29. Differential Bevel Pinion Mate Shaft
30. Hypoid Bevel Drive Gear Screw
31. Drive Gear Screw Locking Strap
32. Differential Centre Block
33. Differential Bearing Cup

- 13. Differential Bearing Adjusting Shims
- 14. Hypoid Bevel Drive Gear and Pinion Set (Matched)
- 15. Pinion Bearing Positioning Shims
- 16. Pinion Bearing Cone Shims
- 17. Drive Pinion Oil Seal
- 18. Universal End Yoke Assembly
- 19. Drive Pinion Bearing Oil Slinger
- 20. Drive Pinion Bearing Cone and Roller, Front
- 21. Drive Pinion Bearing Cone and Roller, Rear
- 22. Drive Pinion Bearing Cone and Roller, Side
- 23. Drive Pinion Bearing Cone and Roller, Opposite
- 24. Drive Pinion Bearing Cone and Roller, Opposite
- 25. Drive Pinion Bearing Cone and Roller, Opposite
- 26. Drive Pinion Bearing Cone and Roller, Opposite
- 27. Drive Pinion Bearing Cone and Roller, Opposite
- 28. Drive Pinion Bearing Cone and Roller, Opposite
- 29. Drive Pinion Bearing Cone and Roller, Opposite
- 30. Drive Pinion Bearing Cone and Roller, Opposite
- 31. Drive Pinion Bearing Cone and Roller, Opposite
- 32. Drive Pinion Bearing Cone and Roller, Opposite
- 33. Drive Pinion Bearing Cone and Roller, Opposite
- 34. Differential Gear Carrier Cover Gasket
- 35. Axle Shaft Grease Retainer, Inner
- 36. Axle Shaft Bearing Grease Connection
- 37. Axle Shaft Bearing, Cone and Roller
- 38. Differential Bearing Shims
- 39. Brake Shoe Anchor Pin
- 40. Brake Shoe and Lining Assembly

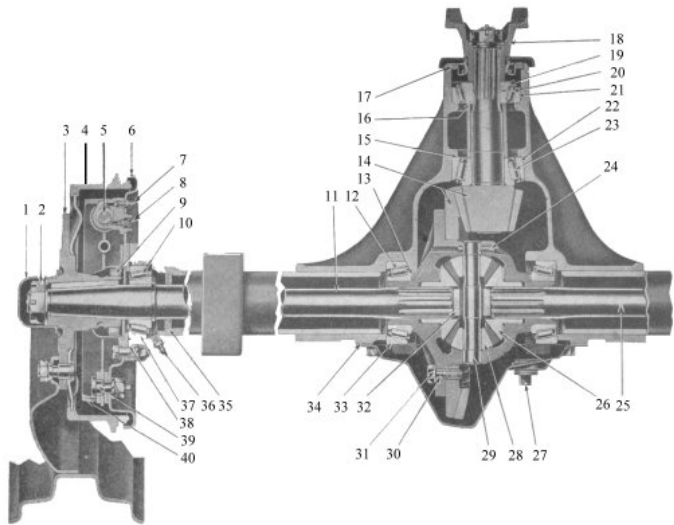

FIG. 27 -- REAR AXLE ASSEMBLY
(Semi-Floating Type)

[Return to The CJ2A Home Page](#)

CJ2A Operation and Care Manual -- Proper Maintenance (part 6 -- Brakes)



BRAKES

The foot or service brakes are hydraulically actuated in all four wheels. The brakes are of the two-shoe, double anchor type and have chrome-nickle alloy iron drums. The hand brake is mechanically operated through a cable and conduit to an internal expanding type brake mounted on the propeller shaft at the rear of the transfer case.

FOOT BRAKES

In operation, pressure is applied to the hydraulic liquid in the master cylinder through the foot pedal, forcing the liquid through the lines and into the wheel cylinders. The pressure forces the pistons in each wheel outward, expanding the brake shoes against the drums. As the pedal is further depressed, higher pressure is built up within the hydraulic system, causing the brake shoes to exert greater force against the brake drums. As the brake pedal is released the brake shoe return springs pull the shoes together forcing the fluid out of the cylinders and back into the lines toward the master cylinder.

The master cylinder may be reached by removing the five screws in the inspection cover on the toe board below the steering column. Keep the master cylinder reservoir full at all times. Use only genuine hydraulic brake fluid. Check the level each 1000 miles and use care, when removing the filler cap, that no dirt enters the reservoir. The fluid capacity is approximately 3/4 pts.

The hydraulic brake system must be bled whenever a fluid line is disconnected or air enters the system due to low fluid level in the master cylinder reservoir. A leak in the system may be indicated by a "spongy" pedal. Air trapped in the system is compressible and does not permit pressure, applied to the brake pedal, to be transmitted solidly to the brakes. Should bleeding be required, consult your Willys-Overland Dealer.

BRAKE SHOE ADJUSTMENT - MINOR

When the brake lining becomes worn the effective brake pedal travel is reduced. The effective travel may be restored by adjusting the brake shoes.

First make sure that there is 1/2" pedal travel, without moving the master cylinder piston, which is necessary to prevent the brakes from dragging due to expansion of the hydraulic liquid.

Jack up the wheels to clear the floor. Adjustment is made by relocating the brake shoe eccentrics Fig. 28. Loosen the lock nut for the forward brake shoe and hold the nut while turning the eccentric toward the front of the car, with another wrench, until the shoe strikes the drum. Turn the wheel with one hand and release the eccentric until the wheel turns freely then hold the eccentric and tighten the lock nut. To adjust the reverse or rear shoe, repeat this operation except turn the eccentric toward the rear of the car. Do this on all brakes and check the fluid level in the master cylinder reservoir.

As pressure is equal in all parts of the system, the brakes are self-equalizing.

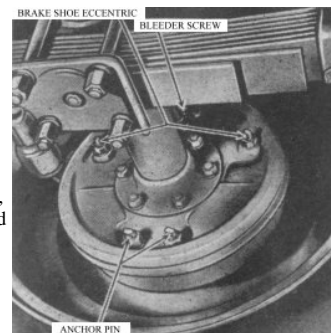

FIG. 28 -- BRAKE ADJUSTMENTS

HAND BRAKE

To adjust the hand brake the sequence below should be followed:

Make sure that the brake handle on the instrument panel is fully released. Give due attention to the cable and operating linkage to see that they do not bind. Should the cable fail to slide freely into the conduit, remove and lubricate it.

Rotate the brake drum until one pair of the three sets of holes are opposite the two adjusting screw wheels in the brake. Use the edge of the holes as a fulcrum for a suitable adjusting tool or a screw driver, rotate each notched adjusting screw by moving the handle of the tool away from the centre of the drive shaft until the shoes are snug in the drum. Back off *seven* notches on each adjusting screw wheel to secure the correct running clearance between the shoes and the drum.

Should either the foot or hand brakes require relining or other extensive work, contact your Willys-Overland Dealer.

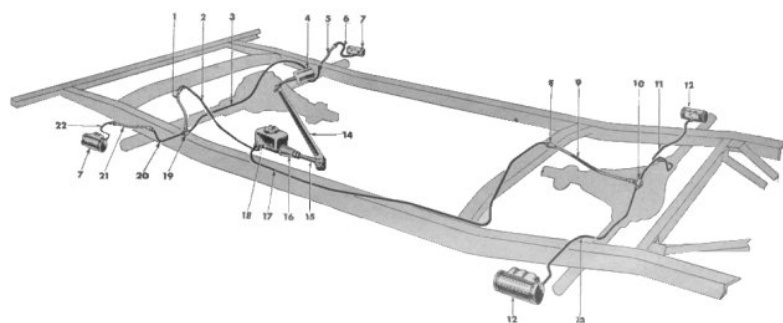

- | | |
|---|---|
| 1. Brake Hose - Front Axle to Frame | 12. Wheel Brake Cylinder - Rear |
| 2. Brake Tube - Master Cylinder to Front Hose | 13. Brake Tube - Rear Axle Tee to Left Rear Brake |
| 3. Brake Tube - Tee to Front Brake Hose, Right | 14. Brake Pedal Shaft |
| 4. Brake Pedal | 15. Master Cylinder Eye Bolt |
| 5. Brake Hose - Front Axle | 16. Master Cylinder Boot |
| 6. Brake Tube - Wheel Cylinder to Hose | 17. Brake Tube - Master Cylinder to Rear Hose |
| 7. Wheel Brake Cylinder - Front | 18. Brake Master Cylinder |
| 8. Brake Hose Spring Lock Clip | 19. Rear Axle Tee |
| 9. Brake Hose Assembly | 20. Brake Tube - Tee to Left Front Brake Hose |
| 10. Rear Brake Tee | 21. Brake Hose - Front Axle |
| 11. Brake Tube - Rear Axle Tee to Right Rear Axle | 22. Brake Tube - Wheel Cylinder to Hose |

[Return to The CJ2A Home Page](#)

CJ2A Operation and Care Manual -- Proper Maintenance (part 7 -- Steering and Suspension)

Go to the
CJ2A
Page
Home Page

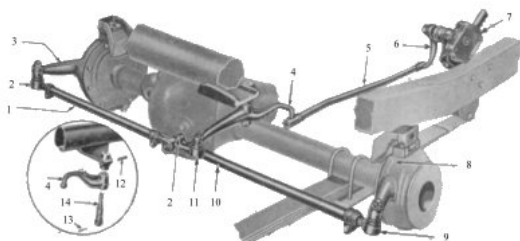

FIG. 30 -- STEERING SYSTEM

- | | |
|-------------------------------|------------------------------------|
| 1. Tie Rod - Right | 8. Knuckle and Arm - Left |
| 2. Tie Rod Socket - Right | 9. Tie Rod Socket - Left |
| 3. Knuckle and Arm - Right | 10. Tie Rod - Left |
| 4. Steering Bell Crank | 11. Socket Assembly |
| 5. Steering Connecting Rod | 12. Steering Bell Crank Pin |
| 6. Steering Gear Arm | 13. Steering Bell Crank Cotter Pin |
| 7. Steering Gear Arm Assembly | 14. Steering Bell Crank Shaft |

STEERING SYSTEM

The "Steering System" is illustrated in Fig. 30. It requires little attention other than proper lubrication and maintaining correct alignment. Alignment may be thrown out by striking curbs or other obstructions.

Looseness in the steering system will also affect alignment. It is impossible to satisfactorily align front wheel without first adjusting the various connections, including the front wheel bearings.

The correct toe-in of the front wheels is $3/64"$ – $3/32"$ which must be accurately measured for satisfactory front tire wear and steering. The best method of checking wheel alignment is by the use of the wheel alignment device, which is available in most every well equipped shop.

Periodic inspection and tightening of the steering parts will aid greatly in maintaining alignment. Keep the steering connection rod and tie rod ball joints snug; they must operate freely without lost motion. Keep the steering gear arm No. 6 tight on the lever shaft and the steering housing bracket tight on the frame. For adjustment of the front wheel bearings see the next section, "Front Wheel Bearings".

The bell crank No. 4 is mounted on the frame front cross tube and swivels on two needle bearings. The mounting shaft is removable from the frame bracket by driving out a tapered locking pin. The bell crank tie-rod ball is replaceable. Should the bell crank become bent or damaged, install a new part.

Do not tighten the steering gear to dampen out steering trouble. Should trouble develop, consult your Willys-Overland Dealer, as he has a definite procedure for the inspection and adjustment of the steering system.

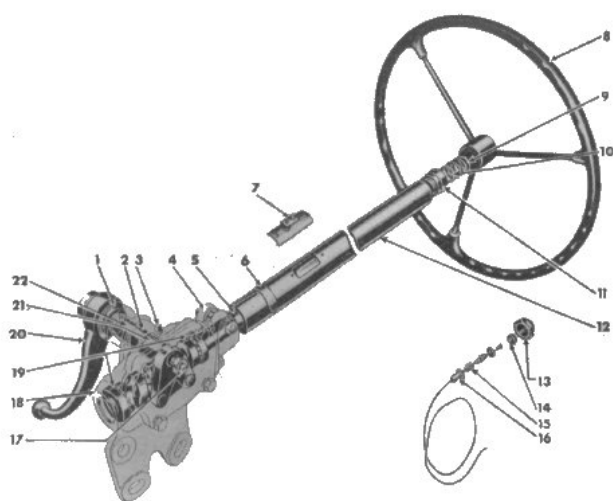

- | | |
|--|--|
| 1. Housing Oil Seal | 12. Steering Column & Bearing Assembly |
| 2. Lever Shaft Assembly | 13. Steering Wheel & Horn Button Nut |
| 3. Housing Oil Filler Plug | 14. Horn Button |
| 4. Steering Column Clamp Assembly | 15. Horn Button Spring |
| 5. Cam & Wheel Tube Assembly | 16. Horn Button Spring Cup |
| 6. Steering Column Oil Hole Cover | 17. Side Adjusting Screw |
| 7. Horn Wire Contact Brush Assembly | 18. Housing Assembly |
| 8. Steering Wheel | 19. Cam Bearing Balls |
| 9. Steering Column Bearing Spring | 20. Steering Gear Arm |
| 10. Steering Column Bearing Spring Set | 21. Housing Bushing - Inner |
| 11. Steering Column Bearing Assembly | 22. Housing Bushing - Outer |

FRONT WHEEL BEARINGS

The front wheels are mounted on two opposed tapered roll bearings. These bearings are adjustable for wear and their satisfactory operation and long life depends upon periodic attention and correct lubrication. Loose front wheel bearings may cause excessive wear and will affect front wheel alignment. If the bearing adjustment is too tight, the rollers may break or become overheated.

To check the adjustment, first raise the front of the vehicle so that the tires clear the floor. Check the brakes to be sure they are free and fully released. With the hands, check sidewise shake of the wheel. If the bearings are correctly adjusted, shake of the wheel will be just perceptible and the wheel will turn freely with no drag.

Should the test indicate that adjustment is necessary, remove the hub cap axle shaft nut, washer, driving flange and shims. See Fig. 25. Wheel bearing adjustment will then be accessible. Bend the lip of the nut locking washer so that the adjustment lock nut and washer can be removed. Rotate the wheel and tighten the adjusting nut until the wheel binds slightly. Then back off the nut 1/6 turn, or more if necessary, making sure the wheel turns freely without sidewise shake. Replace the locking washer and lock nut and bend over the locking washer lip. Check the adjustment and reassemble the driving flange, nut and hub cap, being sure to replace the shims.

REAR WHEEL BEARINGS

Each rear wheel is carried on a single tapered roller bearing which is adjusted by shims placed between the brake backing plate and the axle flange.

Check wheel bearing adjustment in the same manner as the front wheel. Should the check determine that adjustment is required, remove the hub cap; remove the cotter pin, the axle shaft nut and use a wheel puller to remove the wheel hub. Remove the bolts holding the brake dust shield, the grease and bearing retainer and the brake assembly. Remove or install shims, Fig. 32, No. 2 to adjust the bearing with .001" to .003" end float which will be just perceptible when tested by hand. The shims available for this adjustment are .003" - .005" and .030" thick.

Examine the grease retainer to be sure it is serviceable -- replace it if in doubt, and reassemble.

MAINTENANCE OF WHEEL BEARINGS

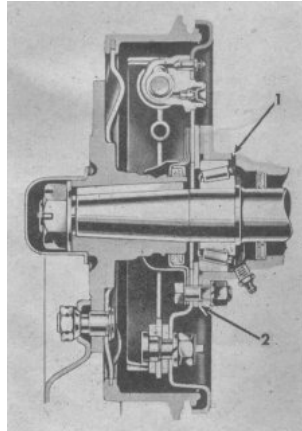

FIG. 32 -- REAR WHEEL HUB AND BEARING

When the vehicle is used for road work, lubricate and adjust the front wheel bearings once each year; if used in dusty field work, twice each year.

The bearings should be given more than casual cleaning. Use a clean stiff brush and suitable grease solvent to remove all particles of old lubricant from the bearings and hubs. After the bearings are thoroughly cleaned, inspect them for pitted races and rollers and check the hub oil seals.

Repack the bearing cones and rollers (see "[Lubrication Section](#)") and reassemble in the reverse order of dismantling. Adjust them as directed in the preceding paragraphs.

Lubricate the rear wheel bearings sparingly. Oil forced from the oil relief hole No. 1, Fig. 32, indicates when the bearing is amply lubricated.

Should it be necessary to adjust the bearings, clean them thoroughly and repack them with the recommended lubricant.

MOUNTING AND DISMOUNTING WHEELS

The wheel mounting nuts and studs on both left wheels have left hand threads to prevent them from being loosened by wheel action. The studs are identified by an "L" stamped on the end. The left hand threaded nuts are identified by a groove cut around the hexagonal faces. To remove the left wheels, the nuts must be turned RIGHT, and to remove the right wheels, turned to the LEFT.

TIRES

The recommended tire pressures are as follows:

6:00 x 16 Tires	28-30 lbs.
7:00 x 15 Tires	20-21 lbs.

The importance of correct tire inflation cannot be overemphasized. To secure the maximum tire life and most efficient vehicle operation, it is imperative that these pressures be maintained for all normal vehicle operations.

Then the vehicle is used with driver only doing agricultural work on very sandy or muddy soil, increased flotation and wheel traction may be secured by decreasing the pressure of the 6:00 x 16 tire to 18 to 20 lbs., and the 7:00 x 15 tire to 14 lbs. Should unusual operating conditions require this reduction in pressure, use care that the tires are inflated to the recommended pressure immediately when normal operation is resumed.

To secure maximum tire wear, the wheels should be switched at least twice each year. The rear wheels should be moved to the opposite front positions and the right front wheel moved straight back to the right rear position. Place the spare on the left rear and use the left front as a spare.

To remove a tire from a drop centre rim, first deflate completely and then force the tire away from the rim throughout the entire circumference until the bead falls into the centre of the wheel rim, then with a heavy screw driver or tire removing tool, used opposite the valve, remove one side of the tire at a time and remove the inner tube.

Installation of a tire is made in the same manner by first dropping one side of the tire into the centre of the rim and with a tire tool, spring the bead over the wheel rim, using care not to damage the inner tube.

When mounting the wheel, alternately tighten opposite stud nuts to prevent wheel wobble. After nuts have been tightened with the wheel jacked up, lower the jack so wheel rests on the floor and retighten the nuts.

SPRINGS AND SHACKLES

The springs should be periodically examined for broken or shifted leaves, loose or missing rebound clips, angle of the spring shackles and the position of the springs on the axle saddles. Springs with shifted leaves do not have their normal strength. Missing rebound clips may permit the leaves to fan out or break on rebound. Broken leaves may make the vehicle hard to handle or permit the axle to shift out of line. Weakened springs may break causing difficulty steering.

The front springs are interchangeable, as are the two rear.

The front ends of the front springs and the rear ends of the rear springs are shackled, using "U" type shackles with threaded bushings. The rear ends of the front springs and the front ends of the rear springs are bronze bushed and pivoted on bolts in the shackles mounted on the frame.

The spring shackle threaded bushings use right and left hand threads, depending upon where they are to be used. Six bushings are used with right hand threads and two with left hand threads. For identification the right hand threaded type have plain hexagonal heads. The left hand have a groove cut around the heads.

The two left hand threaded shackles can be identified by a small forged boss on the lower shank of the shackle. They are used at the left front and the right rear springs with the left hand threaded end down at the spring eyes.

The bushings are anchored solidly in the frame brackets and spring eyes and the oscillation taken between the threads of the "U" shackle and the inner threads of the bushings. The lubrication of the shackle bushings is very important and should not be neglected, or excessive wear of the bushings and "U" shackles will occur.

When making installation of a new "U" shackle or bushing, follow the procedure below:

The shackles are installed with the bushing hexagon heads to the outside of the frame. Install the shackle grease seal and retainer over the threaded end of the shackle up to the shoulder. Insert the new shackle through the frame bracket and the eye of the spring. Hold the "U" shackle tightly against the frame bracket and start the upper bushing on the shackle, care being taken when it enters the thread in the frame, that it is not cross-threaded. Screw the bushings on the shackle about halfway, and then start the lower bushing, hold the shackle tightly against the spring eye and thread this bushing about halfway, then alternating from top bushing to lower bushing, turn them in until the head of the bushing is snug against the frame bracket and the bushing in the spring eye is 1/32" away from the spring measured from the inside of the hexagon head to the spring.

Lubricate the bushings with high pressure lubricant and then try the flex of the shackle, which should be free. If the shackle is tight, it will cause spring breakage and it will be necessary to rethread the bushings on the shackle.

SHOCK ABSORBERS

The shock absorbers are of the direct action type giving two-way control, however they are not adjustable. They dampen spring action, as the vehicle passes over irregularities in the road. The shock absorbers are mounted on rubber bushings at both top and bottom. Should squeaks occur in the bushings, add a flat washer on the mounting pins to place the bushings under greater pressure and prevent movement between the rubber and metal parts.

DO NOT USE mineral oil to remove squeaks.

[Return to The CJ2A Home Page](#)

CJ2A Operation and Care Manual -- Proper Maintenance (part 8 -- Cold Weather Precautions)



With the approach of cold weather, in regions where the temperature drops below the freezing point, precautions must be taken to prevent freezing of the water in the cooling system. When water freezes it expands and may burst the radiator and cylinder block.

Be careful to drain the system completely (see "[Cooling System](#)") when putting up the vehicle in cold weather, unless it is kept in a heated garage or an anti-freeze solution has been added to the water to sufficiently lower the freezing point of the cooling mixture.

ANTI-FREEZE SOLUTION

It is important that the cooling system be made leak-proof before installing any anti-freeze solution. Should there be any doubt regarding the condition of either the radiator or heater hoses, replace them.

Common anti-freeze solutions available are alcohol and ethylene glycol. The distillation or evaporating point of alcohol solution is approximately 170° Fahrenheit. The operating temperatures of the Jeep when used as a farm tractor and especially when used for belt work through the power take-off is somewhat higher. As a result, alcohol will not be satisfactory to use as an anti-freeze due to evaporation. Should it be necessary to use it, the solution must be checked often with a hydrometer to guard against damage due to freezing. Alcohol is satisfactory for highway use, however it must be checked frequently to make certain that freezing will not occur at anticipated temperatures.

Ethylene glycol has a much higher evaporating point than alcohol, so may be used at higher operating temperatures without loss of the solution. In a tight cooling system, water only is required to replace evaporation losses, however, any solution lost mechanically through leakage or foaming must be replaced with additional solution.

The capacity of the cooling system is 11 qts. The following table shows the correct quantity of both alcohol and ethylene glycol for protection at the various temperatures indicated:

Temp. Fahr.	ALCOHOL			ETHYLENE GLYCOL		
	U.S. Qts.	Imperial Qts.	Metric Litres	U.S. Qts.	Imperial Qts.	Metric Litres
30°	1	4/5	0.946	1	4/5	0.946
20°	2 1/8	1 4/5	2.011	2	1 2/3	1.892
10°	3 1/4	2 4/5	3.075	3	2 1/2	2.839
0°	4 1/4	3 3/4	4.022	3 3/4	3 1/8	3.549
-10°	5	4 1/8	4.732	4 1/2	3 3/4	4.258
-20°	5 1/2	4 1/2	5.205	4 3/4	4	4.495
-30°	6 3/4	5 2/3	6.388	5 1/2	4 1/2	5.205
-40°	7 1/4	6	6.861	6	5	5.678

The engine should be operated to thoroughly mix the solution.

ENGINE OIL

In cold weather it is important that a lighter grade of engine oil be used so that the engine may be started easily and to assure an adequate flow of oil to every part of the engine. Use oil having a low cold test which will not congeal at the temperature to which it will be subjected.

GEAR LUBRICATION

Hard shifting of the transmission gears in cold weather is a positive indication that the transmission lubricant is either too heavy grade or the quality allows it to congeal at the prevailing temperature. This condition will also probably apply to the transfer case and the differentials. If the oil is too heavy to allow ease in shifting, it is too heavy to properly lubricate the close fitting parts. Change the lubricant to a lighter grade without delay.

[Return to The CJ2A Home Page](#)

CJ2A Operation and Care Manual -- Emergency Chart)



No adjustment should be made, or any parts tampered with, until the cause of the trouble is ascertained, otherwise adjustments which are properly made may be destroyed. The trouble should be analyzed first.

STARTING MOTOR WILL NOT TURN ENGINE

- Battery weak.
- Battery connection dirty or loose.
- Battery or engine ground wire connections loose.
- Battery to starting motor wire connections loose at starting motor end.
- Starter switch contacts dirty.
- Starter gear stuck.

ENGINE FAILS TO START

- No fuel.
- No ignition current (see om7). May be due to failure to turn on the switch or to a broken or disconnected wire.
- Spark plug points improperly set. Set to .030 inch (0.76 mm.).
- Distributor points improperly set. Set to .020 inch (0.51 mm.).
- Cylinders or manifold flooded with fuel. With ignition switch on, choke open (control pushed all the way in), hold accelerator all the way down and rotate the engine which will reduce the fuel supply in the cylinders.
- Moisture on high tension terminals of the spark plugs or distributor cap. Wipe terminals dry with a rag.
- Gas mixture too lean. Choking is necessary to start cold engine.

ENGINE STOPS

- Lack of fuel.
- Disconnected wire.
- Lack of oil.
- Carburetor flooding.
- Engine overheated.
- Distributor breaker points dirty or pitted.

ENGINE MISSES AT ALL SPEEDS

- Faulty wiring.
- Fouled spark plugs. The spark plugs should be short circuited one after another by touching a hammer or wood handle screw driver from the cylinder to the terminal of each spark plug. When one is reached which makes no difference in the running of the engine, it is an indication that the plug is at fault. Remove and clean. If porcelain insulator is cracked, install new plug.

- Spark plug points improperly set.
 - Points too close together or too far apart may cause missing.
 - Spark plug points should be set to .030 inch (0.76 mm.).
 - Accumulation of carbon or oil on spark plug porcelain.
 - Corrosion on end of spark plug cables at distributor cap connection.
- Distributor faulty.
 - Breaker arm sticking.
 - Points improperly set or burned and pitted.
 - The correct point opening is .020 inch (0.51 mm.).
- Faulty condenser or coil.
- Water in fuel.
- Engine overheated.

ENGINE MISFIRES AT LOW SPEED ONLY

- Intermittent flow of fuel.
- Poor ignition or compression.
- Distributor points improperly adjusted or making poor contact.
- Incorrect timing.
- Faulty condenser.
- Spark plug points are too far apart (on pull) or too close together (on idle).
- Air leak at intake manifold connections.

LOSS OF POWER

(The engine will run but will not pull the car under a heavy load.)

- Ignition improperly timed.
- Lack of fuel or carburetor flooding.
- Dragging brakes.
- Engine overheated because of lack of oil or water.
- Poor compression.
- Improper valve timing.
- Clutch slipping.
- Exhaust pipe or muffler obstructed.

LACK OF COMPRESSION

- Faulty cylinder head gasket.
- Insufficient tappet clearance.
- One or more improperly fitted pistons or piston rings.
- Valves not seating properly.

POPPING BACK THROUGH THE CARBURETOR

(This usually indicates a too lean mixture.)

- Dirt in carburetor. (Fuel pump strainer dirty, see "[Fuel System](#)".)
- Water in fuel.
- Air leak at intake manifold connections.

- Incorrect ignition timing.
- Incorrect valve timing.
- Inlet valves holding open.
- Spark plug wires connected to incorrect plugs. Firing order 1-3-4-2.

ENGINE OVERHEATING

- Lack of proper lubrication.
- Stoppage of water circulation, faulty thermostat or lack of water.
- Slipping fan belt.
- Ignition timing improperly set.

[Return to The CJ2A Home Page](#)

CJ2A Operation and Care Manual -- Extra Equipment)

Go to the
CJ2A
Page
Home Page



Much of the utility of the Jeep is due to the extra equipment which has been designed to adapt it for farming and diversified occupations and industries. The maintenance and use of this equipment is outlined in the following paragraphs.

GOVERNOR (KING SEELY)

The governor is a centrifugal type unit which gives precision control of engine speeds. When speed control is not desired it should be disengaged with the twin-pin type clutch No. 1, Fig. 33. Never engage this clutch with the engine running. To operate it pull the cap outward and rotate it $\frac{1}{4}$ turn in either direction until you feel the two lugs drop into the recesses provided. The governor is engaged when the lugs are in the deeper recesses. The shallow recesses lock it in the disengaged position. Some governor clutches are controlled by a spring loaded lever mounted at the top of the governor housing the operation of which is obvious.

The belt tension may be adjusted by raising or lowering the governor in the slotted mounting holes Fig. 34, No. 11. Keep the pulleys and belt free of dirt and oil. Belt slippage will effect governor operation and a tight belt may cause rapid wear of the governor shaft and bearings. Adjust it to allow 1" depression midway between the pulleys with thumb pressure.

The controlled engine speed may be varied with the hand control mounted on the dash. With this control in against the dash, the controlled engine speed is 1000 rpm. The speed is increased 200 rpm. Per notch, as the hand control is pulled out. The top speed is 2600 rpm. In the 9th notch. The hand control is released by turning the handle $\frac{1}{4}$ turn in either direction.

When the governor is to be used, stop the engine, engage the governor clutch and pull the hand throttle fully out to allow the governor to take over engine speed control. When the governor clutch is disengaged, release the hand throttle by $\frac{1}{4}$ turn in either direction.

GOVERNOR ADJUSTMENT

Mechanical adjustment of speed control is obtained by adjusting the length of hand cable control assembly No. 5, Fig. 34.

First check the carburetor throttle rod to make certain the throttle opens and closes fully. Disconnect the accelerator spring and eliminate any bind or stiffness in the throttle connections and carburetor linkage. Free operation of the throttle is necessary to prevent surging of the governor when the engine is placed under load. After checking, reconnect and leave it there.

Set the dash hand throttle in the fully open position and leave it there. All the adjustments are made with the throttle in this position.

Adjust the length of the spring loaded governor-to-throttle link No. 13 to allow exact assembly between the short or lower governor lever and the carburetor throttle lever without moving either lever and with the throttle fully open. The length of the link after adjustment should be approximately 6" between the centres of the ball sockets. Tighten the adjustment lock nut and install the spring loaded governor-to-throttle link.

Engage the governor clutch by turning the control on the pulley hub until the pins drop into the deeper recesses. Place the governor hand control, mounted on the instrument panel, in the closed or "IN" position and check to be sure the hand throttle is fully open. Start the engine and allow it to run until operating temperature is reached.

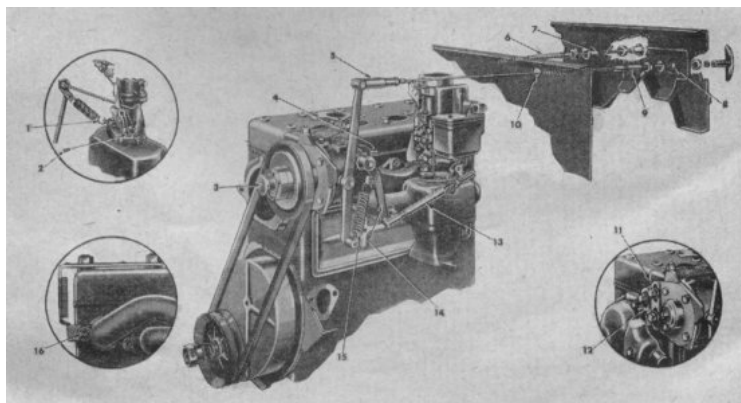

FIG. 34 GOVERNOR INSTALLATION AND ADJUSTMENT

The governed engine speed is controlled by the position of the upper or long governor lever. Adjust the yoke No. 5, Fig. 34 on the hand control cable and attach it to the governor arm when the arm is positioned to give an engine speed of 1000rpm. Safely jack up the rear wheels and be sure the front wheel drive is not engaged. When driving the rear wheels in high or direct transmission gear, the speedometer will read 15 mph. at an engine speed of 1000 rpm.

In some cases it maybe necessary to adjust the surge screw at the rear of the governor to eliminate surge. Should this be necessary, loosen the lock nut and turn the slotted screw until the engine stops surging when the governor hand control is suddenly operated from low to high speeds then tighten the lock nut. Use care in making this adjustment: should the screw be turned in too far, governor speed control will be lost.

GOVERNOR (MONARCH)

Some vehicles are equipped with the Monarch governor. This governor is similar in design and operation to the King Seeley type described above. However, engagement is through a spring loaded lever control mounted at the top of the governor body. To engage the drive unlatch the control lever and allow the spring to carry the engaging clutch forward.

When adjusting this governor follow the above instructions in every detail except the adjustment of the spring loaded governor-to-throttle link No. 13. Adjust this link with approximately $\frac{1}{16}$ " slack or lost motion. No surge adjustment is required or provided with this governor, however this slack or lost motion is provided to cushion any slight irregularities in governor control.

MAINTENANCE

Change the oil in the governor at each engine oil change, using the same grade oil used in the engine. Fill it to the level plug opening slowly -- do not overfill. Should any trouble occur which requires disassembly, consult your Willys-Overland Dealer.

POWER TAKE-OFF WITH SHAFT AND BELT PULLEY

The complete power take-off consists of three assemblies; the shift unit (mounted on the transfer case), the shaft drive assembly and the pulley drive assembly (mounted at the rear of the vehicle). The rear units are driven through the shaft assembly by a propeller shaft and two universal joints.

The assembly, mounted at the rear of the vehicle, is designed to drive trailed equipment or operate belt driven machines. The shaft and pulley speeds conform to SAE standards and are obtained at the maximum torque speed of the engine. For information covering the power take-off shaft and pulley speeds, see the chart on the "[Power Take-Off and Vehicle Speeds](#)" page.

FRONT UNIT OR SHIFT ASSEMBLY

This assembly, attached to the rear of the transfer case and operated from the transmission main shaft, provides a gear shift for control of the power take-off. The shift assembly is lubricated from the transfer case and no attention is required other than the regular lubrication of the transfer case.

Keep the attaching screws tight at all times. Always disengage the clutch when shifting the gear. When using the belt drive, do not attempt the shift until the machine being driven has "coasted" to a stop.

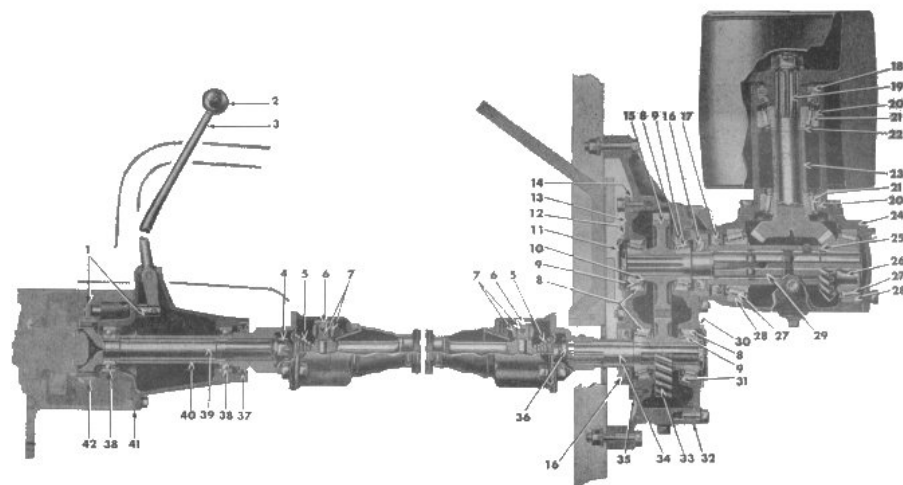

FIG. 35 -- POWER TAKE-OFF ASSEMBLY

1. Fork and Rod	8. Cup	15. Gear	22. Shims	29. Shaft	36. Washer
2. Ball	9. Bearing	16. Oil Seal	23. Spacer	30. Gasket	37. Oil Seal
3. Lever	10. Snap Ring	17. Oil Seal	24. Shims	31. Shims	38. Ball Bearing
4. Nut	11. Plate	18. Oil Seal	25. Shims	32. Gasket	39. Gear and Shaft
5. Spring	12. Gasket	19. Gear and Shaft	26. Pinion	33. Gear	40. Spacer
6. Button and Spring	13. Retainer	20. Cup	27. Cone and Roller	34. Shaft	41. Gasket
7. Trunnion and Ball	14. Gasket	21. Cone and Roller	28. Cup	35. Gasket	42. Sleeve

PROPELLER SHAFT AND UNIVERSAL JOINTS

The power take-off propeller shaft is tubular and has two universal joints. The joints are enclosed by housings and boots, which contain the lubricant. The torque capacity of the propeller shaft is far greater than that developed by the engine and as there is very little flexing of the joints, this unit will require no attention for the life of the vehicle under normal use other than an inspection at each regular vehicle inspection, to guard against loose companion flange attaching screws or leakage of lubricant at the boots. Should the power take-off be used often for continuous operation, disassemble the joints and repack them with lubricant once each year.

POWER TAKE-OFF SHAFT DRIVE

The six-splined 1 3/8" power take-off shaft provides a power output to operate trailed equipment.

Always use four wheel drive when towing power driven equipment. Selection of the most satisfactory governed engine speed, as well as transmission and transfer case gear shift positions will depend upon the soil conditions and the power required to pull the trailed equipment; also when operating agricultural machines, upon ground and machine speed requirements and crop conditions.

When towing power driven farm machines, under average conditions, the most satisfactory operation will be secured by using either No. 5 or No. 6 governor position with both the transmission and transfer case gears in the low range position. This engine speed and gear combination provides a ground speed of from 4 to 4 1/2 miles per hour and a power output shaft speed of 535 to 600 rpm. Under extremely heavy crop conditions it may be found that the machine being operated cannot handle the volume of the crop which is cut at this ground speed. To handle the crop, it is necessary to reduce the ground speed without changing the power output shaft speed. This is accomplished by interchanging gears No. 33 and No. 15 as shown in Fig. 35. These two gears form a drive ratio within the power output unit of either 20 to 24 (5 to 6) or 24 to 20 (6 to 5). The original factory assembly is made to provide a ratio of 20 to 24 – the 20-tooth gear assembled on the input shaft and the 24-tooth gear on the output shaft as shown in Fig. 35.

To interchange the gears, first remove the power take-off assembly from the vehicle and drain the lubricant from the housing. Remove the bearing retaining plate No. 11, Fig. 35. Bend back the lips of the nut locking washer and remove the bearing retaining nut. The cover may then be removed with the bearing assembly. Use care not to lose the shims which are placed between the gear hub and the bearing cone. The gear may be slipped from the shaft through the cover opening.

The other gear may be removed in the same manner after removing cover plate. Interchange the gears and reassemble in reverse order with the long side of the gear hub toward the cover opening. Use care that the shims are replaced in the same position relative to the bearings from which they were removed. Do not overlook refilling the housing with lubricant.

The speed of the output shaft in relation to the vehicle ground speed is important. To aid in the selection of engine speeds and gear ration positions, refer to the chart on the "Power Take-Off and Vehicle Speeds" page which shows both the shaft and vehicle speeds through the range of governor controlled engine speeds and in all transmission and transfer case gear positions.

CAUTION: When the vehicle is reversed, the shaft drive will turn in the reverse direction. Some farm machines will be damaged if reverse driven. When operating trailed equipment, be sure to disengage the power take-off with the shift lever before reversing the vehicle. Being able to reverse some power driven machines is an advantage to aid in freeing the machine should it become clogged in operation.

Inspect the power take-off unit periodically and add sufficient lubricant to keep it at filler plug level. Keep the attaching screws tight at all times and the breather or vent free of dirt.

When using the shaft drive, always install the shield which is provided for the safety of the operator.

PULLEY DRIVE ASSEMBLY

The pulley drive assembly, with 8" pulley, is driven through the power take-off shaft. It is held in position with four cap screws and can be quickly removed or installed. Always remove this assembly when it is not in use to avoid damage through accident.

When operating the pulley drive assembly use care that the vehicle is correctly aligned so the belt runs at the centre of the pulley. Do not tighten the belt excessively: when too tight, rapid wear of the drive parts of both the machine being driven and pulley drive assembly may occur. If correctly adjusted the hand brake will hold the vehicle when ample drive tension is placed on the belt.

The belt pulley drive is operated from the transmission main shaft, giving the same power and speed ratios that are provided by the transmission for the vehicle on the highway. To operate the pulley with the vehicle standing, place the auxiliary (right hand) transfer case lever in the neutral position, designated as "N" in Fig. 3.

The nine governor controlled engine speeds in conjunction with the transmission gear shift positions provide a large selection of pulley speeds. Select the governor and transmission gear shift positions that will provide the recommended speed of the machine being driven. Machines driven below this speed will seldom do a satisfactory job while speeds above normal will cause rapid wear and are, in some cases, dangerous. The table on the "[Power Take-Off and Vehicle Speeds](#)" page is provided as a guide in selecting the correct control positions to secure the recommended speed.

CAUTION: When the belt drive is used, ground the vehicle with a bar or piece of chain so static electricity is dissipated or sparks might cause a fire in dusty or inflammable surroundings.

Keep the housing filled with lubricant to the level of the filler plug. (See "[Lubrication Chart](#)".)

FRONT PULLEY DRIVE UNIT

The front pulley drive unit which may be installed at the rear of the power take-off front or shift unit is used to drive compressors, pumps, generators, etc., mounted in the vehicle to the right and behind the drivers seat. The 6" pulley may be wither two or four-grooved for multiple "V"-type belt drives and will deliver up to 23 horsepower.

When multiple drive belts are used it is important that each belt carry an equal share of the load. While this type belt had a steel core, some stretching may occur, and should one belt break or become damaged, all should be replaced. Should the belts be removed, mark them to permit reinstallation on the same pulleys from which they were originally removed. Do not tighten the belts excessively.

BODY ENCLOSURE

Both front and rear canvas body enclosures are available. The front enclosure may be installed independently and the side curtains which are mounted on steel frames are hinged to open as doors. The hinge pins may be lifted from sockets to allow quick removal of the doors.

The rear enclosure is attached to the front top and is provided with curtain lights in each side. A rear curtain with light completes the enclosure.

As a general rule good quality soap and water will clean the windows in the curtains. Should they become soiled with grease, kerosene or naphtha may be used.

Avoid the use of benzene, acetone or lacquer thinners, as they will soften the surface and make the windows opaque. Many spray type window glass cleaners contain some of these ingredients, so avoid their use.

Rubbing the windows with a dry cloth will build up an electrostatic charge which will cause dust to cling to the surface. Such a charge may be dissipated by blotting the window surface with a clean, damp chamois. After cleaning apply a liberal coating of automobile or furniture wax as a protection against dirt.

FRONT ENCLOSURE INSTALLATION

First select the front top bow assembly parts. The two side bows are offset at the lower ends and eyes are located near the top curved ends. The centre connecting bow has an eye located at the centre.

Assemble the centre bow in the two side bows, with the eyes extending toward the windshield and mount the assembly in the body sockets.

The doors are supported at the top and bottom with hinge support brackets which are not interchangeable as they are made in rights and lefts.

Select the upper brackets which are made as clamps; the large jaws are formed to span the windshield support and the small jaws to form the door hinge socket. Select a set of jaws (one having a clamp stud) which will assemble with the hinge socket vertical and in line with the bracket mounted on the body below.

Also select the correct upper side rail (a rod approximately 30" long with one end curved) which will assemble with the curved end next to the windshield with the curve extending up and out and with the welded eye extending in.

After selecting the correct parts install the clamp bracket, with the stud extending in and place the eye in the curved end of the side rail over the stud on the inside of the clamp bracket. Tighten the stud nut with the clamp bracket positioned so the side rail is level with the top of the windshield. Attach the rear end of the side rail to the eye on the top bow with the bolt lockwasher and nut provided. Make the same assembly on the opposite side.

Next install the attaching side curtains which carry the door latches. The right and left sides may be easily selected as the lap of the seam goes inside. Place the upper end of the rod in the curtain through the eye mounted on the side rail and attach the lower end at the holes provided in the body. Place the bolt heads on top.

Place the top deck covering over the top bow and attach the front end on the fasteners across the top of the windshield. Fasten the covering to the top bow with the two outer flaps. Hook one end of the centre supporting brace in the eye at the top centre of the windshield frame and make the covering taut by hooking the rear end in the top bow eye. Fasten the centre top attaching flap over the rear end of the supporting brace.

Snap the door jambs, which are part of the top covering, around the side rails at the top of the door openings.

Install the doors and attach the front sides to the body and windshield supports. It is necessary to open the windshield to button the upper fasteners.

Attach the rear curtain, pulling the holding straps at the bottom taut only.

REAR ENCLOSURE

Assemble the centre section of the rear top bow between the side sections and install the assembly in the body sockets. Place the top over the bow and fasten the front end to the rear of the front top.

The side curtains are made for the right and left sides, but when correctly installed the straps are at the bottom and on the inside and the cutout corners are placed at the upper rear. Install both the side and rear curtains. Attach and pull down the straps taut only.

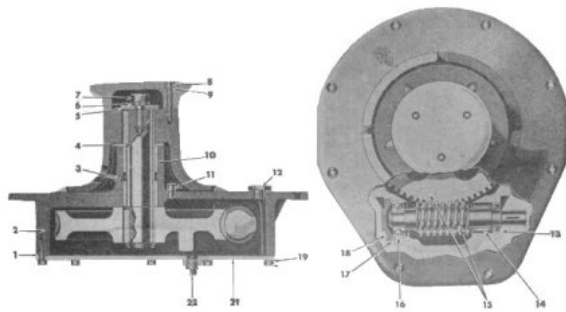

FIG 36 -- CAPSTAN WINCH

- | | |
|-----------------------------------|---|
| 1. Cover Plate Gasket | 12. Filler Plug |
| 2. Gear Box | 13. Worm Shaft Oil Seal |
| 3. Capstan Shaft Grease Fitting | 14. Worm Shaft Needle Bearing |
| 4. Capstan Shaft Thrust Washer | 15. Worm and Gear Set |
| 5. Capstan Shaft Retaining Screw | 16. Worm Shaft Ball Bearing |
| 6. Capstan Shaft Screw Lockwasher | 17. Bearing Retainer Cap Gasket |
| 7. Capstan Shaft Screw | 18. Bearing Retainer Cap |
| 8. Cover Screw | 19. Gear Box Cover Plate Screw |
| 9. Cover Screw Lockwasher | 20. Gear Box Cover Plate Screw Lockwasher |
| 10. Capstan Shaft Bushing (Upper) | 21. Cover Plate |
| 11. Capstan Shaft Bushing (Lower) | 22. Drain Plug |

CAPSTAN WINCH

The capstan winch is designed for 5000 lb. Pull, using either ¾" or 1" manila rope. The worm gears have a ratio of 75 to 1 which provides a rope speed of 19 feet per minute with an engine speed of 1200 rpm. A shift lever is mounted on the assembly for engagement control.

Engage the drive with the engine idling only and without load: limit the engine speed to 1200 rpm.

Lubrication is important because the parts must withstand high pressures when operating at maximum pull. Filler and drain plugs are provided in the gear housing with an oil level stick on the filler plug. The oil capacity is one quart of SAE 90 gear oil in Summer and SAE 80 in Winter. Change the oil twice each year – in Fall and Spring.

Hydraulic fitting No. 3, Fig. 36, is provided to lubricate the capstan spindle, the position of which is indicated by the arrow cast on the gear box. To lubricate the spindle, align the opening in the capstan with arrow. Use chassis lubricant to lubricate the spindle, also lubricate the rope roller at each end and the shift rail and the drive shaft bushing in the winch drive support bracket mounted on the front of the engine. Use an oil can to lubricate the winch drive universal joints.

A cotter pin is used to pin the winch drive shaft to the universal joint at the engine end and acts as a shear pin to prevent overloading. Should this pin shear off, be sure to replace it with a cotter pin of the same size. Do not replace it with a solid pin or drill the hole oversize for a larger pin.

FRONT BUMPER WEIGHT

The best performance of a four-wheel drive vehicle is achieved when the load is equally distributed for traction on the front and rear wheels. This equal distribution is disturbed when the vehicle is used for draw bar work because the load on the rear wheels is increased and that on the front wheels decreased. The addition of a 265-pound front bumper weight equalizes this load.

When the load is equalized the front and rear axles do approximately the same work which results in an equal and prolonged life of these parts and more satisfactory vehicle performance.

The bumper weight Fig. 37 is held in place by four bolts and is provided with hand holes for lifting. Do not add sand bags or other weights in the vehicle. When driving over rough terrain, with the bumper weight in place, the driver should exercise due care.



FIG. 37 -- FRONT BUMPER WEIGHT

CJ2A Operation and Care Manual -- Plowing Method, PTO and Vehicle Speeds)



Method of Plowing with the Universal Jeep

To avoid loss of time and minimize turning at the headlands while plowing a field, the following procedure is recommended:

Lay out the field lengthwise in convenient lands or sections as shown by the back furrows in Fig. 38. The width of the lands will vary according to the field size; however, make the lands as near ten rods in width as possible. Should the lands be too narrow, time will be lost in turning at the headlands and in completing dead furrows; if too wide, time will be lost in driving across the headlands.

Plow a shallow marker furrow across each end of the field, parallel with and 20 feet from the end, to act as a guide in keeping the headlands straight.

Set up a target at each end of the field to indicate the line of the first back furrow.

Plow a furrow between the headland marks, using the target as a guide to keep the furrow straight and parallel with the edge of the field. Turn and plow a second furrow against the first to complete the back furrow. It is advisable to have the plow set to turn a shallow furrow and use care that the second furrow does not overlap the first, otherwise an objectionable ridge will be formed the length of the field. Next adjust the plows for standard depth and plow around the back furrow until the unplowed space at the side of the field is equal to the width of the headlands previously marked off.

Throw a new back furrow in the same manner at the next back furrow line and plow around it until the unplowed portion between the lands equals that which has been plowed around the new back furrow. To reduce driving distance, plow around the unplowed portion between the two back furrows until it is completed to form a dead furrow. When plowing the dead furrow, set the plows shallow to prevent forming an objectionable trench the length of the field.

Continue with new lands, started by back furrows, until the width of the unplowed ground at each side of the field equals the marked-off headlands at each end of the field.

If it is desired, to prevent close turns, the operator may plow one side of a back furrow returning across the field plowing the opposite side of the next back furrow. Plowing around the two back furrows until the two plowed sections are wide enough to allow easy turns may save some time.

Next plow the headlands around the field. Plow the ground out toward the edge: next time the field should be plowed in toward the centre. If it is decided to plow "out", start at the outer edge, plowing around the field until the headlands are completed. This will leave a dead furrow around the field at the inner edge of the headlands. To plow "in", start at the inner edge of the headlands and the dead furrow will be at the outer edge of the field.

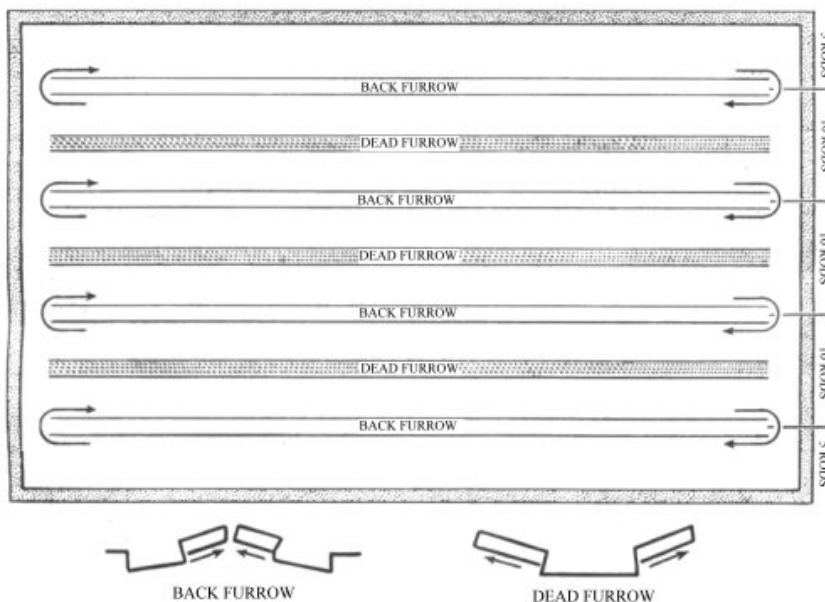

FIG. 35 -- FIELD LAYOUT FOR PLOWING

Power Take-Off and Vehicle Speeds

To satisfactorily operate most power-driven equipment, the operator should know the speed of the power take-off shaft or

the belt pulley as well as the vehicle ground speed. A great variety of speeds are made available by the manual governor control, the gear ratios in the transmission and transfer case and by interchanging the gears in the power take-off housing.

The tables below indicate the speeds for each of the nine positions of the manual governor control. Note that the shaft speeds are all computed with the vehicle in four-wheel drive and that of the belt pulley in the transmission drive only. Reference to these tables will be of material assistance especially in the operation of the farm combine or grain separator.

**Power Take-off Shaft Speeds (R.P.M.) and Vehicle Ground Speeds (M.P.H.)
Power Take-Off Gear Ratios**

Governor Control Positions	Transfer In	20-24 RATIO Transmission Gear In						24-20 RATIO Transmission Gear In						Engine Speed
		Low		Intermediate		High		Low		Intermediate		High		
		Take-Off Shaft RPM	Vehicle Speed MPH	Take-Off Shaft RPM	Vehicle Speed MPH	Take-Off Shaft RPM	Vehicle Speed MPH	Take-Off Shaft RPM	Vehicle Speed MPH	Take-Off Shaft RPM	Vehicle Speed MPH	Take-Off Shaft RPM	Vehicle Speed MPH	
1	Low High	298 298	2.22 5.40	537 537	4.01 9.75	833 833	6.22 15.13	428 428	2.22 5.40	773 773	4.01 9.75	1200 1200	6.22 15.13	1000
2	Low High	357 357	2.67 6.48	644 644	4.81 11.71	1000 1000	7.47 18.15	514 514	2.67 6.48	928 928	4.81 11.71	1440 1440	7.47 18.15	1200
3	Low High	417 417	3.11 7.56	752 752	5.62 13.66	1166 1166	8.72 21.17	600 600	3.11 7.56	1083 1083	5.62 13.66	1680 1680	8.72 21.17	1400
4	Low High	476 476	3.56 8.65	859 859	6.42 15.61	1333 1333	9.96 24.20	685 685	3.56 8.65	1237 1237	6.42 15.61	1920 1920	9.96 24.20	1600
5	Low High	536 536	4.00 9.73	967 967	7.22 17.56	1500 1500	11.20 27.22	771 771	4.00 9.73	1392 1392	7.22 17.56	2160 2160	11.20 27.22	1800
6	Low High	595 595	4.44 10.81	1074 1074	8.02 19.51	1666 1666	12.45 30.25	857 857	4.44 10.81	1547 1547	8.02 19.51	2400 2400	12.45 30.25	2000
7	Low High	655 655	4.89 11.89	1182 1182	8.83 21.46	1833 1833	13.70 33.27	942 942	4.89 11.89	1702 1702	8.83 21.46	2640 2640	13.70 33.27	2200
8	Low High	714 714	5.34 12.97	1289 1289	9.63 23.41	2000 2000	14.94 36.31	1028 1028	5.34 12.97	1856 1856	9.63 23.41	2880 2880	14.94 36.31	2400
9	Low High	774 774	5.78 14.05	1396 1396	10.43 25.36	2166 2166	16.19 39.33	1114 1114	5.78 14.05	2011 2011	10.43 25.36	3120 3120	16.19 39.33	2600

Pulley Speeds (R.P.M.) -- 8" Pulley. Power Take Off Gear Ratios.

Governor Control Position	20-24 RATIO Transmission Gear In			24-20 RATIO Transmission Gear In			Engine Speed
	Low	Intermediate	High	Low	Intermediate	High	
1	255	460	714	367	663	1028	1000
2	306	552	857	440	795	1234	1200
3	357	645	1000	514	928	1440	1400
4	408	737	1143	587	1061	1645	1600
5	459	829	1285	660	1193	1851	1800
6	510	921	1428	734	1326	2057	2000
7	561	1013	1571	807	1458	2262	2200
8	612	1105	1714	881	1591	2468	2400
9	663	1197	1857	954	1723	2674	2600

CJ2A Operation and Care Manual -- Directions for Ordering Parts)



When new parts are necessary, it is recommended that these be ordered from the nearest Willys-Overland Dealer.

Do not order parts in a letter in which some other subject is treated.

When ordering parts for a particular vehicle, give the model, engine, and serial number of the vehicle.

The serial number will be found stamped on plate located on the outside of the left frame side rail at the front end, and at the left side of the driver's seat on the floor riser.

Engine number will be found stamped on top of the water pump boss at the front end of the cylinder block.

Never order in sets, but give the exact quantity of the parts desired.

Specify both the part number and the name of the part in full, and if similar parts are used on both the right and left-hand sides, specify for which side you want the new part or parts, because many parts made for right and left sides are not interchangeable.

If in doubt as to the parts needed, take the broken parts to your dealer, or send them to the factory by prepaid express. Write your name and address plainly on the package, so that it can be identified when received.

Write, stating what you are sending and the purpose for which it is sent regardless of any previous correspondence. All parts are held until advice is received.

Give definite shipping instructions – whether the new parts are to be sent by express, freight or parcel post.

In ordering parts by telegram, be sure to send the message prepaid and to confirm it by written order, bearing notation, "Confirm Wire Order."

NOTE: Parts replaced under the terms of the [Warranty](#) must be left with the Willys-Overland Dealer who makes the replacement, if full credit is expected.

This is important for owners to know when traveling outside the territory in which their vehicle was originally purchased, particularly when credit for old parts cannot be established to satisfaction of the Dealer.

In this connection, a forwarding address should be given by the owner in order to insure the receipt of proper credit.

ACCEPT ONLY GENUINE FACTORY PARTS

[Return to The CJ2A Home Page](#)
